

## John Deere X700 Signature Series Diesel ROPS Cab



\*\* Shown with optional equipment

### John Deere JDx730-20 Signature Series ROPS Cab

This ROPS cab is designed and built to fit:  
John Deere X700 Signature Series Diesel models, X750, X754,  
and X758.

Designed and built by:

**Tektite Manufacturing Inc:**  
P.O. Box 639, 427 Buffalo Street  
Winkler, MB, Canada  
R6W 4A8  
PH: 204-331-3463  
[parts@tektite.ca](mailto:parts@tektite.ca)

One-year standard product warranty provided by Tektite Manufacturing Inc.  
[www.tektite.ca](http://www.tektite.ca) / [www.tektitecabs.com](http://www.tektitecabs.com)



**DO NOT PROCEED FURTHER UNTIL YOU HAVE READ THE INFORMATION BELOW.**

- 1) Always wear personal protective equipment.
- 2) A minimum of two people is necessary to safely install the cab.
- 3) This ROPS cab is heavy. A lift assist device such as an overhead hoist or high lift forklift is required.
- 4) Ensure your work area is well ventilated. The installation requires the starting of the tractor which will produce dangerous carbon monoxide fumes.
- 5) Read through the entire installation manual first.
- 6) Follow the installation instructions in order.
- 7) Reading the operators manual prior to using the ROPS cab.

Tektite Manufacturing Incorporated thanks you for purchasing a John Deere X700 Signature Series ROPS cab! Tektite has worked very hard to design and build this ROPS product and we hope that it provides you with many years of protection.

Tektite's products are designed to provide safe and dependable service during operation when they are properly maintained according to the instructions. Please read this installation manual carefully before installing and using this product.

The photos/illustrations provided in this manual may not provide all the detail needed and are for reference only.

All directions provided are from the reference point of the tractor seat facing the steering wheel. All left and right references are from this viewpoint.

For reference, please fill in the information below. This will assist your dealer in providing service for this product. It is advisable that this information be provided to your insurance company as well in the event that the tractor is lost or damaged.

Vehicle Model: \_\_\_\_\_

Tektite Serial Number: \_\_\_\_\_

Date of Purchase: \_\_\_\_\_

Dealer Name: \_\_\_\_\_

**Standard Parts List:****Mounting Parts Bag:**

Description	Qty
Bolt, Hex, 5/8" x 3", Gr. 8, YD	2
Nut, Flange, 5/8", Gr. 8, YD	2
Washer, Flat, 1/4" Thick x 2 1/2", YD	2
Bolt, Flange, 5/16" x 3/4", Gr. 8, YD	4
Nut, Flange, 5/16", Gr. 8, YD	4
Bolt, Hex, 3/8" x 1", Gr. 8, YD	4
Nut, Flange, 3/8", Gr. 8, YD	4
Bolt, Flange, 1/2" x 1", Gr. 8, YD	2
Nut, Flange, 1/2", Gr. 8, YD	2
Wire Connector Loop, 3/8"	2
Wire Connector Loop, 1/4"	2
Step Bolt, 1/4" x 1 1/2", Black	2
Flange Nut, 1/4"	2

**Loose Components:**

Description	Qty
Rear Bracket (Pre-installed onto cab)	1
Front Mounting Brackets	L&R
Fuel Hose (Elbow Hose w/pre-cut cap and fill weldment pre-installed)	1
Seat Belt Kit (pre-installed)	1
NDAX, 3/4" x 3/4"	36"
Floormat for Centre	L&R
Nostril Floormat	1
Air Intake Nostril, Steel (pre-installed weather-stripping)	1

**Heater Parts List (DIESEL ENGINE):**

Description	Qty
Box Heater, Pre-installed onto cab	1
Heater Hose, 5/8" ID (Pre-installed onto heater)	13 FT
Hose Clamp, HS-10	4
Hose Clamp, HS-24	2
Straight Fitting, 3/8NPT x 5/8" Barb	2
Straight Fitting, 16MM male x 3/8NPT Female	1
Radiator Hose Splicer, 1 1/8"	1
Zip Ties, Standard	6

**Optional Quick Disconnect Heater Parts List (DIESEL ENGINE):**

Description	Qty
HS-10 Hose Clamps	4
Fitting, 3/8 NPT x 5/8" Barb, Straight	4
Quick-Disconnect Male Coupler	2
Quick-Disconnect Female Coupler	2

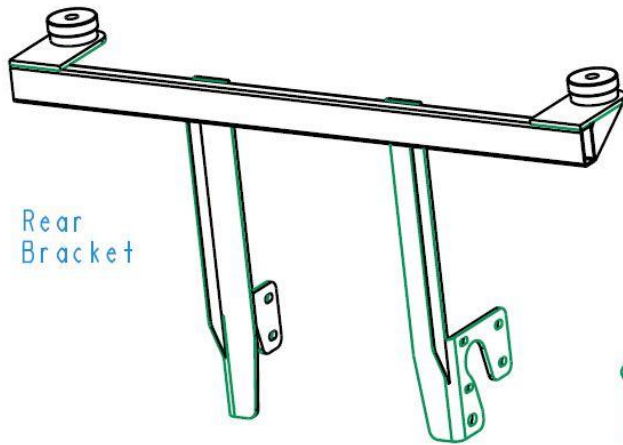

Rear Bracket

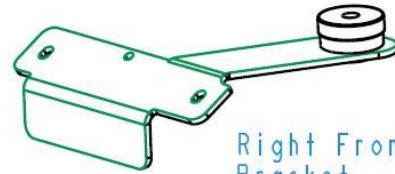

Right Front Bracket

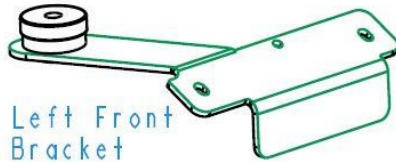

Left Front Bracket



Diesel Fuel Fill Weldment

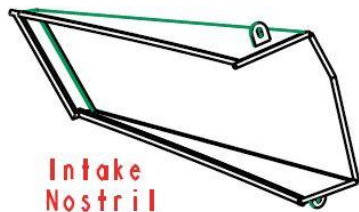

Intake Nostril



Nostril Floormat



Gas Fuel Fill Weldment  
(2 1/2" Ring Bottom)

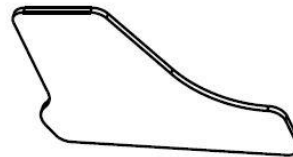

Centre Floormat  
L&R

**Standard Cab Installation Instructions:**

Park the tractor in a well-ventilated area, put the loader down along with all tractor attachments.

1. Open engine hood and locate the left engine mount bushings. Take the front left mount bracket and position it directly underneath the chassis mount and re-use factory hardware. Do not fully tighten until after cab is installed.

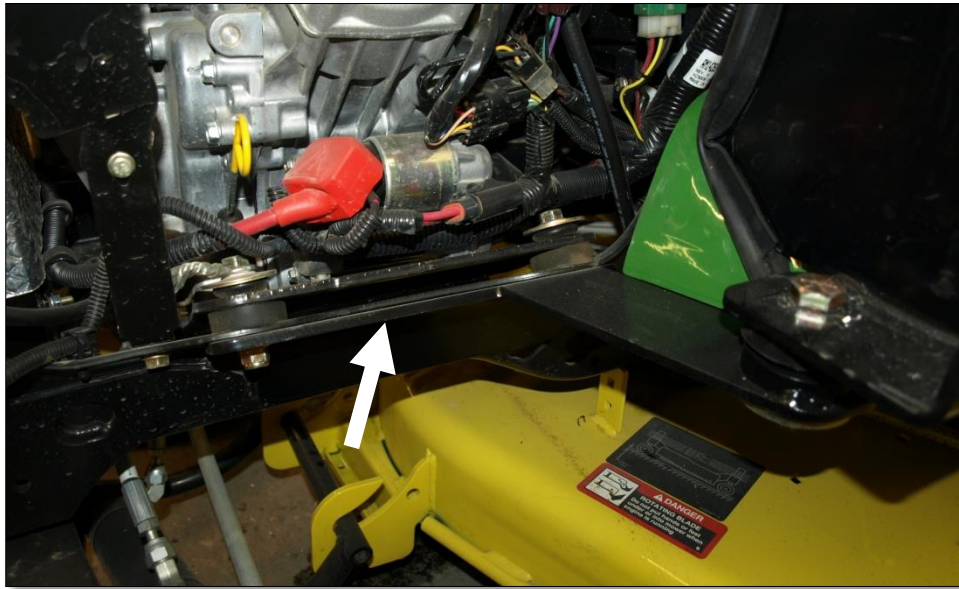

2. Repeat step 1 for the right engine mount bushings and install the front right mount bracket. Do not fully tighten until after cab is installed.

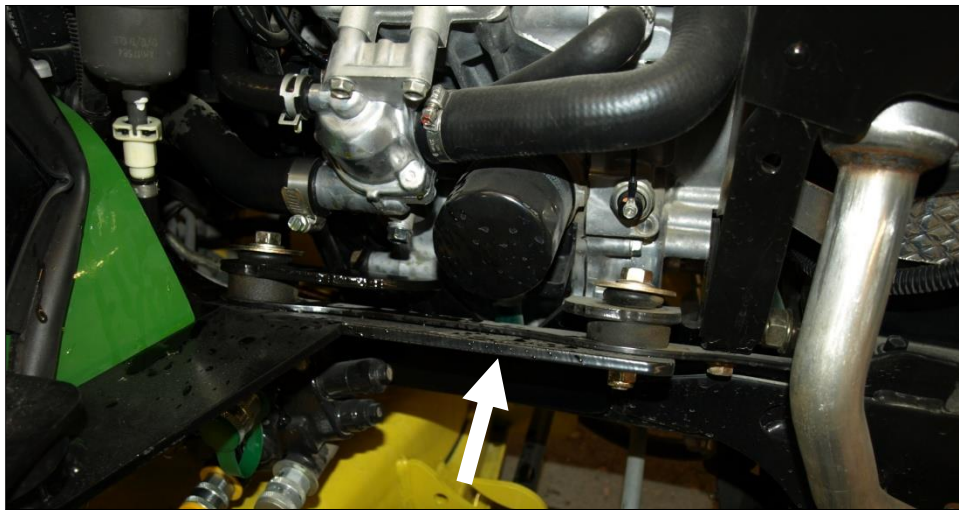

3. Un-bolt and remove the rear bracket from the cab. If the tractor is equipped with the Click N Go bracket set (BM20714) or a rear 3-point, it will be necessary to partially

remove those components during installation of cab rear bracket which goes onto the outside of the rear vertical tractor flange plates. Slide the rear bracket into place, use the following provided fasteners per side to attach to tractor, 1/2" x 1" flange bolt, two 5/16" x 3/4" flange bolts and nuts, and two 3/8" x 1" hex bolts and flange nuts.



4. Un-hook the gas shock on the left door and then lift the door up off of the pin hinges and temporarily store.

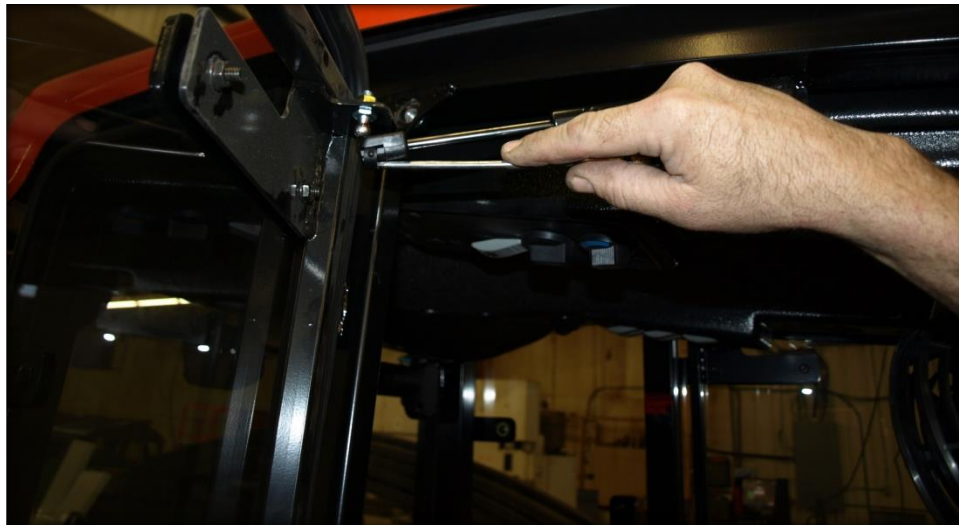

5. Un-bolt and remove the upper right window located directly across from the door.

6. Use a lift strap or chain and route inside of the cab against the b-post. Use foam or rags against the cab frame to prevent any damage to the paint. Connect the straps or chains to an over-head hoist or fork lift and prepare to lift cab up off of the shipping pallet.
7. Remove the fasteners holding the shipping pallet to the cab and lift cab straight up.
8. Position the cab directly over the tractor and slowly lower down onto machine. Hood must be opened, otherwise cab will not clear it. Once the cab is down onto the isolators on the mounting brackets, use the provided 5/8" x 3" hex bolts, heavy flat washer, and flange nuts to bolt the cab to the tractor. The heavy flat washers must be used underneath the brackets to ensure the isolators are tightened properly. See bolt alignment below, very critical!

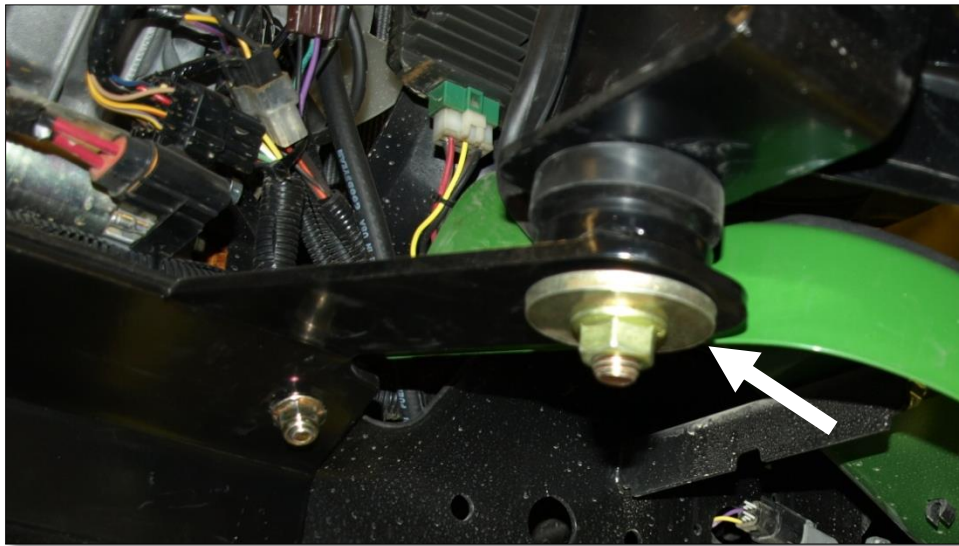

- a. Take 18" of the provided NDAX and install under the rear shield if necessary.





9. Once all fasteners are started, release the over-head hoist completely and remove the lift straps or chains from the cab. Tighten the 5/8" fasteners with 200 ft-lbs of torque. Tighten the 5/16" fasteners to 305 in-lb, 3/8" fasteners to 44 ft-lb, 1/2" fasteners to 107 ft-lb, and the M10 fasteners to 53 ft-lb.
10. Remove the factory fuel filler cap. Use the provided assembly that is pre-installed onto the cab to install the fuel hose onto the fuel tank. Ensure that the rubber washer is seated properly between the steel washer and the top of the fuel neck on mower, and install fuel cap onto fuel tank. If necessary, adjust the orientation of the elbow hose. Please note that the diesel and gas fuel filler necks are NOT interchangeable!



11. **Open windshield in order to open and close the hood. There are rubber draw latches at the bottom of the windshield assembly on both sides.**



12. Route the main power and ground wires from the left A-post of the cab up and into the under-hood area on the left side of the engine. Connect the black wire to a ground on the engine, one of the isolator fasteners. Use the provided 1/4" loop, shorten wire if necessary, then solder connector to black wire. Connect the red wire to the starter. Use the provided 1/4" loop, shorten wire if necessary, then solder connector to red wire.

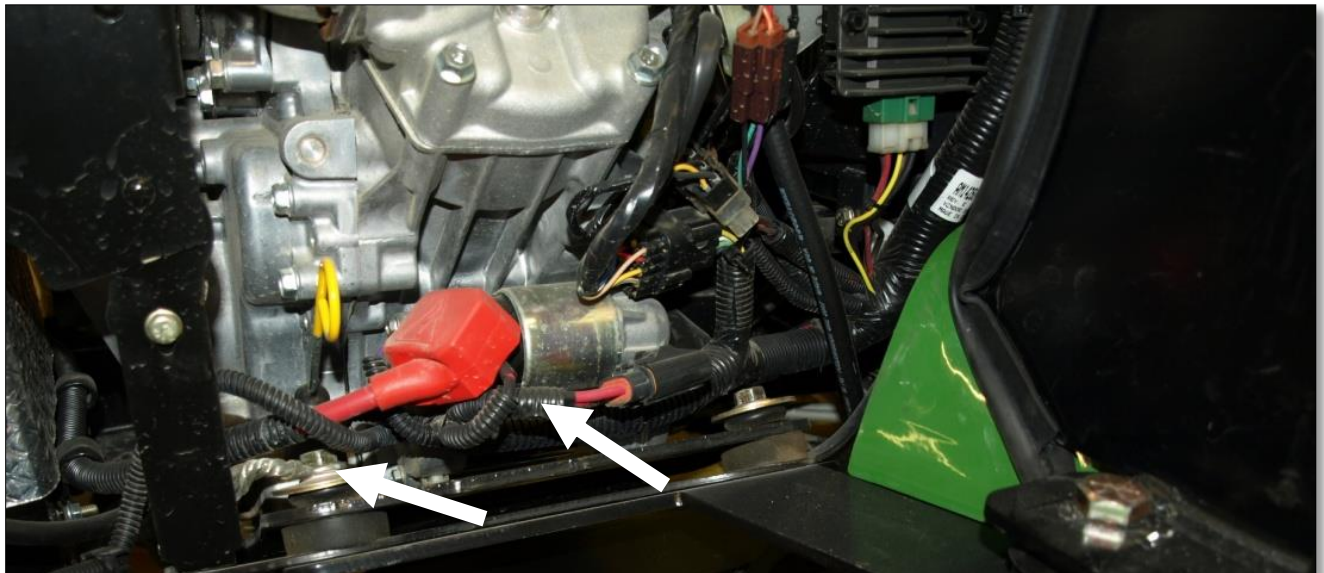

13. Close the tractor hood, then carefully close the cab windshield, but do not fasten closed. Take the provided 3/4" x 3/4" NDAX foam and install onto hood directly against the inside of windshield so that a seal will be tight when hood is fastened closed. ENSURE hood is clean and free of dust and debris prior to removing back adhesive from foam tape.



**For the heater installation, please proceed with the following steps.**

14. Drain engine antifreeze.
  - a. A notch to route the heater hoses is required in the hood. Cut out the portion shown below on the right side of the hood.

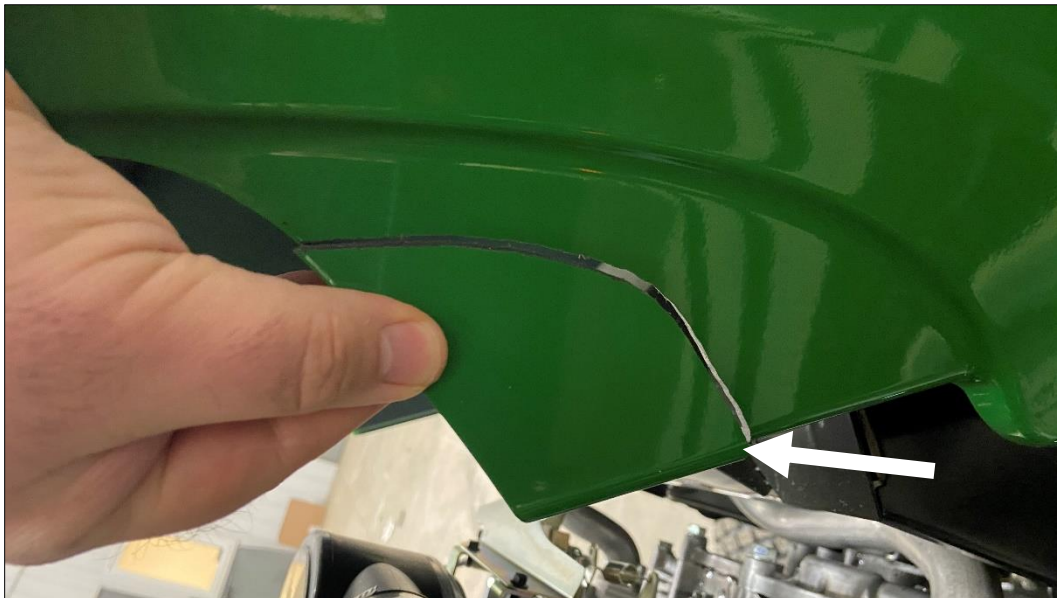

15. Locate the plug shown in the photo on the next page that is on the right side of the engine and remove.



16. Take the provided straight fitting with 16mm thread male and 3/8NPT female, and install into open port, do not over-tighten. Use a silicone tape on the threads of the fitting to prevent water leaks. Install one of the provided straight 3/8NPT x 5/8" barb fittings into the open port of the fitting.
17. Locate the lower radiator hose at the bottom of the engine. At the flat straight section, cut out a short piece, approximately 2" long.

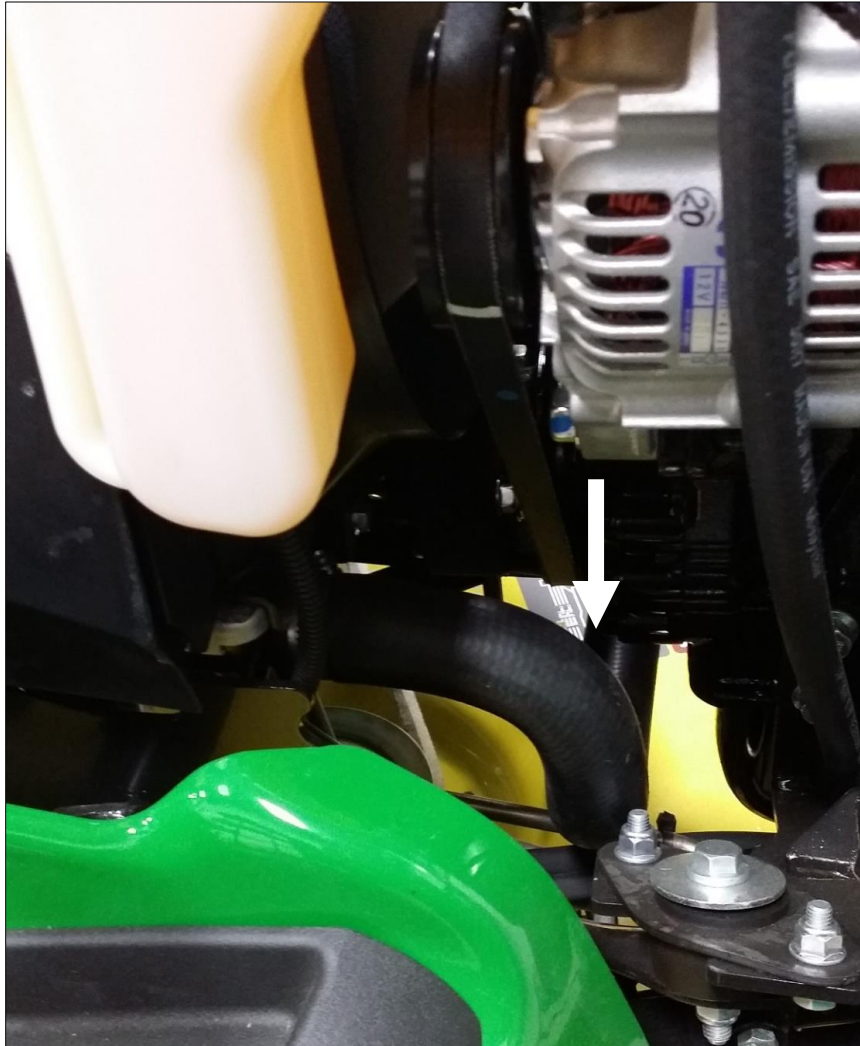

18. Install the remaining 3/8NPT x 5/8" barb fitting into the provided radiator hose splicer. Use a water sealant around the threads of the fitting to prevent leaks.
19. Take the provided radiator hose splicer and install it between the two cut pieces of lower radiator hose. Use the provided HS-24 hose clamps, and securely fasten into place.
20. Route the heater hoses from the right front corner of the cab underneath the engine towards the heater fittings. Cut the hose at the location of the lower radiator fitting. Connect the fitting to the hose with the provided HS-10 hose clamp. Use the provided zip ties to secure the hoses to the tractor away from hot components on the engine and any moving parts.
21. Take the remaining hose and route underneath the engine to the open fitting on the thermostat housing installed earlier. Shorten the hose if necessary, then connect to the reducer with the provided HS-10 hose clamp. Use the provided zip ties to secure the hoses to the tractor away from any moving components or away from hot engine components.

If cab is equipped with quick-disconnect heater kit, install it now.

Please note, the quick-connect fittings have built-in valves to close them when they are disconnected BUT they MUST be connected when removed from cab and tractor.

1. Locate where you would like to install the quick-coupler kit, ideally as close to the engine as possible. **The quick couplers NEED to be reconnected when not in use, so one set of male and female connectors get installed on cab side and one set on the tractor side.**

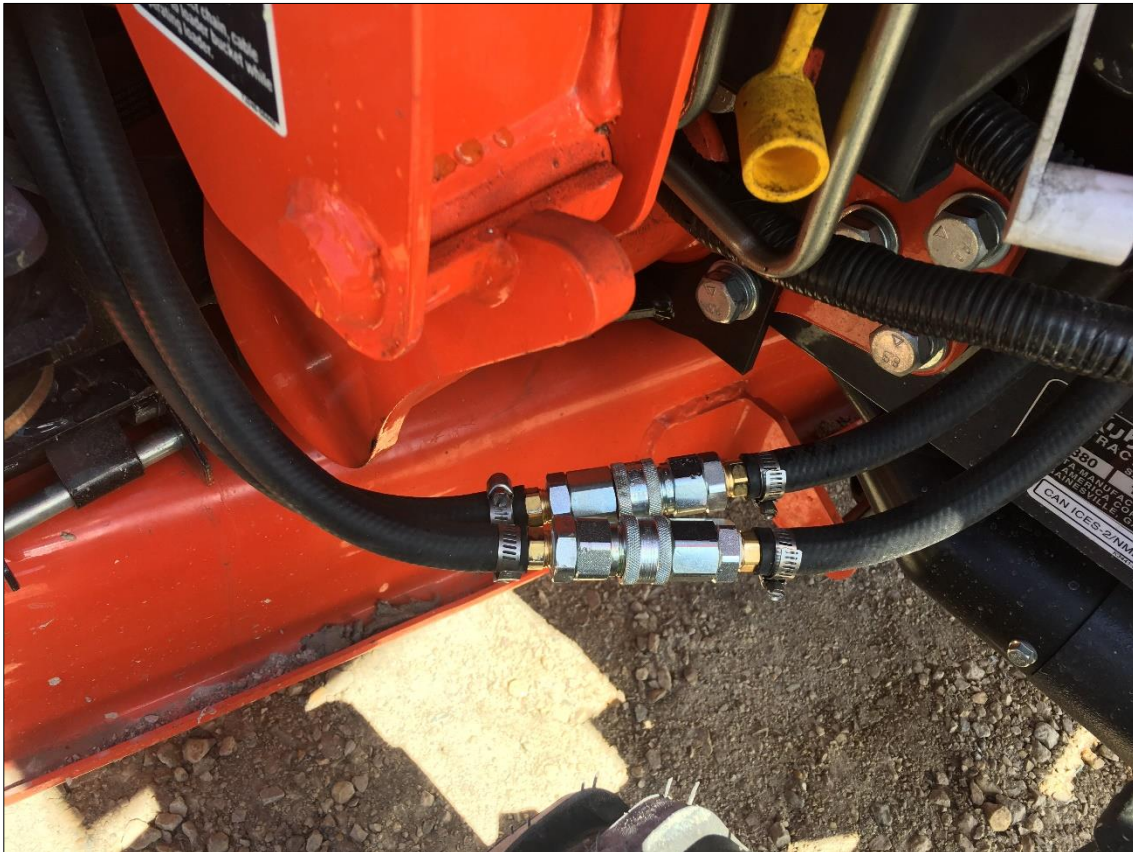

2. Cut the heater hose at this location.
3. Ensure there is water sealant on the threads of the barb fittings. Install the quick-coupler installer in between the ends of the first heater hose.
4. Use the provided HS-6 hose clamps to tighten the hose onto the fittings.
5. Cut the second hose at the location you want this quick-coupler to be located.
6. Ensure there is water sealant on the threads of the barb fittings. Install the quick-coupler in between the ends of the second heater hose with orientation reversed, so that male and female can be re-connected on cab and tractor sides.
7. Use the provided HS-6 hose clamps to tighten the hose onto the fittings.



**Please note, the quick-connect fittings have built-in valves to close them when they are disconnected. There should be no leakage when disconnected.**

8. Make sure all of the fitting connections at the heater and on the engine are tight, and the hoses have been secured to the tractor. Re-fill the engine coolant. Go into the cab and start the engine, then turn on the heater. Turn up the throttle so that the engine will warm up. Remove the radiator cap and place funnel into the opening. Fill the funnel with engine coolant and let the thermostat cycle a few times in order for air-locks to come out of the system. The heater should be producing very HOT AIR at the louvers. NOTE: Ensure that there is adequate fresh air ventilation in the work space you are in, carbon monoxide from the engine exhaust is deadly.

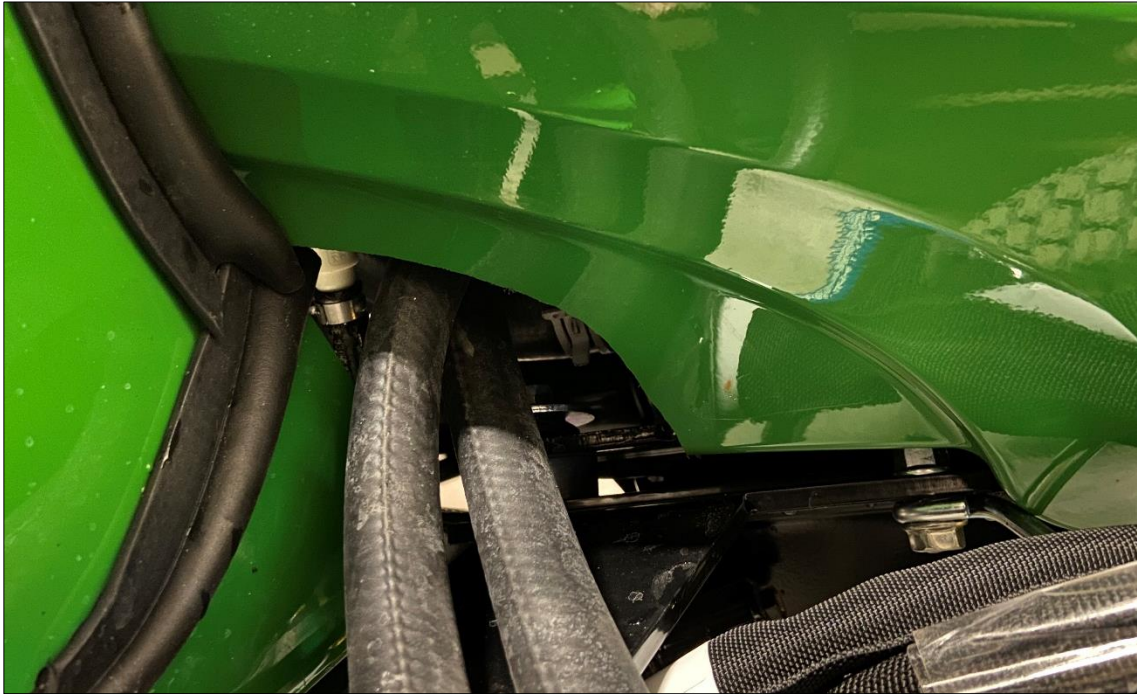

9. To ensure a better seal of all weather stripping and floor mat pieces, it is recommended that you use a black silicone seal to seal the cab parts to the tractor.



**Winter Front Installation Instructions:**

**NOTE: THIS Air Intake Can ONLY be used in the winter months. For spring to fall, it must be removed otherwise engine will overheat.**

1. Remove plastic intake shroud under steering wheel.
2. Take the provided left and right floormat pieces and glue into plastic intake shroud as shown.





3. Re-install air intake shroud with factory hardware.
4. Remove the weather-stripping from the front left shield under the windshield.
5. Re-install weather-stripping on lower left front shield.
6. Take the air nostril and position against the hood and use the provided step bolts through the front shield and flange nuts on the air nostril.



7. Open the hood and place the nostril floormat into the right side of the hood. Glue into place.



## John Deere X700 Signature Series ROPS Short Cab



\*\* Shown with optional equipment

### John Deere X700 Signature Series ROPS Cab

This ROPS cab is designed and built to fit:  
John Deere X700 Signature Series, models X710, X730, X734,  
X738, X739, X750, X754, and X758.

Designed and built by:

**Tektite Manufacturing Inc:**  
P.O. Box 639, 427 Buffalo Street  
Winkler, MB, Canada  
R6W 4A8  
PH: 204-331-3463  
[parts@tektite.ca](mailto:parts@tektite.ca)

One-year standard product warranty provided by Tektite Manufacturing Inc.  
[www.tektite.ca](http://www.tektite.ca) / [www.tektitecabs.com](http://www.tektitecabs.com)



**DO NOT PROCEED FURTHER UNTIL YOU HAVE READ THE INFORMATION BELOW.**

- 1) Always wear personal protective equipment.
- 2) A minimum of two people is necessary to safely install the cab.
- 3) This ROPS cab is heavy. A lift assist device such as an overhead hoist or high lift forklift is required.
- 4) Ensure your work area is well ventilated. The installation requires the starting of the tractor which will produce dangerous carbon monoxide fumes.
- 5) Read through the entire installation manual first.
- 6) Follow the installation instructions in order.
- 7) Reading the operators manual prior to using the ROPS cab.

## Tektite Limited Warranty

Tektite Manufacturing Inc. (“Tektite”) warrants to the original purchaser (the “Claimant”), that Tektite products will be free from defective materials or workmanship, under normal use and service, for a period of (1) full year from the original invoice date. Tektite’s liability under this Limited Warranty is limited to the repair or (at the discretion of Tektite) the replacement of those components of its products, which were manufactured by Tektite that are defective in materials or workmanship. Tektite shall have no liability under this Limited Warranty unless Tektite is notified of the defect during the stated Warranty Period.

Limitations and Exclusions: Tektite has no responsibility to a Claimant under this Limited Warranty or on any other basis for any of the following:

- a) defects caused, in whole or in part, by accident or misuse, negligence or failure to maintain the product or component;
- b) products or components sold to a customer on an “as is” basis;
- c) wiper blades, light bulbs, fuses, clear vinyl or other consumables;
- d) glass where the point of failure has not been preserved intact and delivered to Tektite for analysis of the cause of the failure;
- e) products or components which have been modified after shipping from Tektite to its customer;
- f) transportation charges for returned, repaired or replacement items;
- g) defects that are subject of a Tektite initiated recall where the Claimant fails to comply with the terms of the recall notice that comes to the attention of the Claimant;
- h) components of Tektite products that are manufactured by third parties (Tektite’s only obligation in relation to such components shall be to accord to the Claimant the benefit of any transferable warranty accorded to Tektite by third party manufacturer);
- i) defects in workmanship or materials in products or components that are repaired or replaced by Tektite unless Tektite is notified of the new defect within the Warranty Period that applied to the original product or component that has been repaired or replaced;
- j) defects that result, in whole or in part, from inadequate engineering or specifications provided to Tektite by its customer;
- k) any actual or alleged deficiency in technical or engineering services or advice provided by Tektite to its customer whether provided for valuable consideration or otherwise;
- l) consequential damages, or any other damages whether foreseeable or not, resulting from the defect or any delay in remedying the defect;
- m) any breach or alleged breach of any implied warranty of merchantability or fitness for particular purpose of use;
- n) defects or part failure due to misuse or failure to follow recommended cab installation procedures; and
- o) travel expenses, including mileage.

This Limited Warranty expresses the entire obligation of Tektite, its officers, directors, agents and employees, to its customer or any Claimant in respect of any defect in workmanship, or materials of any product or component sold or manufactured by Tektite whether on grounds of breach of contract, negligence or other tortious liability, breach of express or implied warranty or other basis in law of any jurisdiction.

Acceptance by a customer of delivery of products of Tektite constitutes acceptance of this Limited Warranty in lieu of all other warranties express or implied including without limitation all implied warranties of merchantability or fitness for particular purpose or use and constitutes acceptance by customer of the exclusions and limitations of the liability of Tektite set out above. Once received, the cab should have ALL exterior cardboard, Styrofoam wrapping removed for immediate inspection of product to ensure that no damages have occurred during transportation. Outer coverings should stay off the cab and the cab be stored indoors in a controlled environment. The warranty card must be completed and returned to Tektite.

Warranty claims should be reported to [parts@tektite.ca](mailto:parts@tektite.ca). A warranty claim form and instructions will be provided at this time. Warranty work not pre-authorized by Tektite may not be covered by this warranty agreement. Labor rate and time allowances are fixed by Tektite. Approved warranty claims will be issued in the form of credits applied to customer account.

## Safety Precautions

### *Safety First*

Read these instructions carefully. It is essential that you read the instructions and safety regulations before you attempt to assemble or use the features that are on this cab/ROPS.

**Danger:** Indicates an immediate hazardous situation which, if not avoided, will result in death or serious injury.

**Warning:** Indicates a potentially hazardous situation which, if not avoided, may result in death or serious injury.

**Caution:** Indicates a potentially hazardous situation which, if not avoided, may result in minor or moderate injury.

**Important:** Indicates that cab or property damage may result if instructions are not carefully followed.

**NOTE:** All products are designed to give safe, dependable service if they are operated and maintained according to instructions. It is the owner's responsibility to be certain anyone operating this product reads this manual, and all other applicable manuals, to become familiar with this cab and all safety precautions. Failure to do so could result in serious personal injury or cab damage. If you have any questions, consult your dealer. Read and understand this manual before operation.

**NOTE:** A safe operator is the best assurance against accidents. All operators, no matter how experienced they may be, should read this operator manual and all other related manuals before attempting to operate features in this cab/ROPS and operate the base tractor. Please read the following section and pay particular attention to all safety recommendations contained in this manual and those labelled on the cab and on the tractor.

## General Safety

1. Never let an unqualified or untrained driver operate the tractor.
2. Keep a fire extinguisher, with ABC rating securely fastened in the ROPS. Maintain it and be familiar with its use.
3. Do not carry passengers.
4. Never operate the tractor in a closed building for a prolonged period. Ensure adequate ventilation is present, as engine exhaust fumes are poisonous and can kill.
5. Always keep sleeves, jackets or other loose clothing relatively tight and belted. Loose clothing may catch on moving parts and result in severe personal injury or death.
6. Provide a first-aid kit, securely attached inside of the ROPS for use in case of accident.
7. Never jump from the tractor. There is a danger of tripping or falling on protruding parts.
8. Use steps and hand holds when mounting and dismounting the tractor, or for servicing components too high to reach from the ground.
9. When seated in the ROPS, fasten seat belt before starting the engine. A proper seat belt must be worn at all times when using a ROPS.
10. Safety devices and shields are intended to protect operators from injury or death. Under no circumstances should they be modified, disabled or removed.

## Operating Safety

1. Always operate the tractor controls while sitting in the operator's seat.
2. Lock seat in position and buckle seat belt before operating the tractor.
3. Avoid abrupt sharp turns at high speeds.
4. On sloped terrain, do not make sharp turns as machine stability could be compromised.
5. Operate the tractor smoothly, avoid abrupt starts and stops.
6. Keep all shields in place when operating the tractor.
7. Do not operate the tractor when you are tired, sick, or impaired.
8. Never operate the tractor in confined areas; visibility next to the tractor is reduced. Injury to bystanders or damage to the ROPS or equipment may result.

## Safety

Carefully review the procedures given in this manual and the tractor operator's manual with all operators annually. It is important that all operators become familiar with, and follow safety precautions. Operating instructions must be given to everyone using the tractor before operation and at least once yearly thereafter in compliance with OSHA Regulations 1928.57 (United States).





### **Safe Operation on Rough Terrain**

1. Drive the tractor slowly on hillsides and curves to eliminate the danger of tipping. Avoid slopes which are too steep for safe operation. Avoid sharp uphill turns.
2. Always drive slowly enough over rough ground or obstructions. Drive at speeds slow enough to ensure your safety.
3. When driving out of a ditch, gully, or up a steep hillside, engage the clutch slowly. Avoid sharp uphill turns.
4. When descending steep grades, select a sufficiently low gear to maintain control with minimum use of braking.
5. Use caution when driving near the edge of a ditch or gully. It may cave in, causing the tractor to roll over.
6. Be alert when operating near trees, slopes and around obstructions. Tree branches can cause damage to ROPS components.

### **Maintenance Safety**

1. Remove mud, crop residue, chains, and tools from steps and operator's platform. They may interfere with pedal operation or entry/exit from tractor.
2. When servicing components are too high to reach from the ground use steps and handholds. Do not use fenders or shields that are not designed as steps.

### **Safe Highway Operation**

1. Before operating the tractor on, or near, public roadways check with your local authorities for any local regulations that will affect you.
2. Equip towed implements with slow moving vehicle (SMV) signs when traveling on public roads.
3. Install additional lights on implement rear to safeguard against rear end collisions.
4. Use hazard warning flashers as required by law when transporting or driving on public roads. If the tractor had warning flashers removed when mounting the ROPS, they must be replaced prior to operation on public roads.
5. Keep to the right, yielding right-of-way traffic, especially if pulling implements. Pull off the road and stop to allow motorists to pass. Drive on the road shoulder, if permitted by law.
6. Use extreme caution when pulling heavy loads at road speeds. Avoid hard application of the tractor brakes at high speed.
7. Always drive slowly near curbs, approaches or ditches.
8. If equipped, ensure headlights are aligned so they will not blind the operators of oncoming vehicles. If the tractor is not equipped with turn signals and law requires them, install them prior to operating on or near public roads.
9. Use your turn signals, checking for traffic well in advance of turning. If the tractor is not equipped with turn signals and law requires them, install them prior to operating on or near public roads.

## Safety Decals

1. Keep decals clean. Remove dirt with a wet clean cloth when necessary.
2. Replace safety decals if destroyed, missing, painted over or unreadable. If any safety decals are covered or obscured when the ROPS is mounted, it is recommended that you purchase replacement decals from the tractor manufacturer. Mount them in a readable location at, or near, their original location before operating the tractor.
3. New ROPS decals and tractor decals are available from your tractor dealer.

## ROPS Safety

1. Install the ROPS in accordance with Tektite mounting instructions. Failure to do so may affect the ROPS ability to withstand a roll over.
2. If the ROPS is subjected to alteration, structural damage or involved in an over turn accident, the entire structure must be replaced. Failure to do so may result in injury or death in the event of a roll over.
3. If the tractor is not equipped with seat belts, purchase approved seat belts from the tractor manufacturer or Tektite prior to operating the tractor.
4. Always fasten seat belts prior to operating the tractor.
5. Always operate the tractor from the operator's seat.
6. Remove mud, crop residue, chains and tools from steps and operator's platform. They may interfere with pedal operation or entry/exit from the tractor.
7. Remove all loose chains, tools, and equipment from the operator's platform. Failure to do so may cause injury or death in the event of a roll over.
8. Do not install the ROPS on a tractor model that the ROPS is not designated for (compatible tractor designations are printed on the ROPS serial number plate). The ROPS is designed specifically for individual models to ensure ROPS requirements will be met. Installing the ROPS on a non designated tractor may result in injury or death.

## Emergency Exits

The ROPS cab has two doors. Either one can be used during an emergency.

## Operating Instructions

### Important

The following section locates, identifies, and briefly describes the functions of all cab controls. All operators should familiarize themselves with control location and function prior to operating the tractor. Failure to do so may result in unsafe operation of the tractor and possible injury or death to operators and bystanders.

There is one switch plate located in the cab. The following switches are available, and their functionality is described.



### Cab Switch Plate

#### 1. Front Wiper Rocker Switch (standard)

Low position: Off

High position: On

Note: indicator light activates when wiper is on.

#### 2. Rear Wiper Rocker Switch (not available on all models)

Low position: Off

High position: On

Note: indicator light activates when wiper is on.

#### 3. Front Work Light Rocker Switch (standard)

Low position: Off

High position: On

Note: indicator light activates when work lights are on.

#### 4. Rear Work Light Rocker Switch (optional)

Low position: Off

High position: On

Note: indicator light activates when work light is on.

### **5. Washer Momentary Switch (Front and Rear optional)**

Low position: On

Mid position: Off

High Position: On

### **6. Beacon Rocker Switch (optional)**

Low position: Off

High position: On

Note: indicator light activates when work lights are on.

### **7. Water Heater Fan Rocker Switch (standard)**

Low position: Off

High position: On

Note: indicator light activates when heater is on.

Standard and optional features are individually fused, and the fuses can be accessed behind the plug in the middle of the switch-plate.

## **Cab Circuit Protection**

The Tektite ROPS cab is wired to provide maximum protection against individual circuit overload. All optional components are fused internally behind the cab switch plate. Cab wiring is direct to the tractor battery. DO NOT leave options activated when tractor is not running as battery run down can occur.

Please note: Tektite does have a key switch power option to provide maximum protection against accidental battery rundown and circuit overload. A relay is ignition activated and prevents the operator from accidentally leaving fan motors, lights on after turning the tractor off and leaving for the day. A circuit breaker is provided to prevent the cab electrical components from drawing more power than they should be able to from a dead short. This option can come with your cab if selected or field installed at a later date.

## **John Deere X700 Signature ROPS Cab**

The John Deere John Deere X700 Signature ROPS Cab is designed to provide ROPS protection along with reasonable winter weather protection. The cab design for this model features glass windows at all window locations.

If you are going to be running the tractor with the cab on during the summer months, un-hook the gas shocks on each door, and then lift the doors off of the pin hinges.

## **After your ROPS Cab has been installed:**

Before starting a tractor equipped with a Tektite ROPS cab:

1. Clear the operator platform of all tools. Tools left in or around the ROPS and tractor can cause operator interference which could lead to bodily injury and/or damage the machine.
2. Inspect the ROPS and tractor to ensure all bolts are tight and re-tighten if required.
3. Ensure that all pedals, levers, and controls have adequate clearance for normal operation.
4. Ensure that all electrical components of both the ROPS and tractor operate normally.
5. Ensure your door latches properly onto the striker pin. Immediately after installation, the ROPS frame may flex slightly from installation, and the door latch will need to be re-aligned for proper operation. Loosen the striker pin, striker mounting plate and door latch as necessary to get a proper alignment of the door striker.

## **Service Parts Breakdowns:**

Following are parts breakdowns for components that may require service parts replacement during the life of the ROPS. If you require replacement parts, please contact the dealer that you purchased the ROPS from and indicate which parts you require.



Index				
1	A00-0001	DLP-HANDLE	Outside Push Button Handle	1
2	A00-0002	LEFT-LATCH	Suicide Door Left Latch	1
3	A00-0013	TEKT-0009	5MM Bushing	15
4	A00-0018	STEP-BOLT1-4X1-1-2	Step Bolt, 1/4" x 1 1/2", MB	3
5	A00-0020	STEP-BOLT1-4X1-1-4	Step Bolt, 1/4" x 1 1/4", MB	4
6	A00-0021	FLANGE-NUT-1-4	Flange Nut, 1/4", YD	9
7	A00-0039	TEKT-ASM-001	Left Door Hinge Weldment, Upper	1
8	A00-0040	REID-RST-160-RST-163	Grab Handle	1
9	A00-0041	TEKTITE-DECAL	Tektite Cab Decal - Solid White	1
10	A00-0118	FLANGE_BOLT_1-4X1	Flange Bolt, 1/4" x 1", YD	2
11	A00-0177	TEKT-0068	Handle Washer Spacer	1
12	A00-0228	TEKT-ASM-029	Left Door Hinge Weldment, Lower	1
13	A00-0295	FLANGE_BOLT_M6X30	Flange Bolt, M6x30, YD	1
14	J09-0009	JDX730-070V2-	Door Weatherstripping	1
15	J09-0024	JDX730-092	Door Glass, 1" Short Cab	1
16	J09-0027	JDX730-ASM-36	Door Frame Weldment, 1" Shorter	1

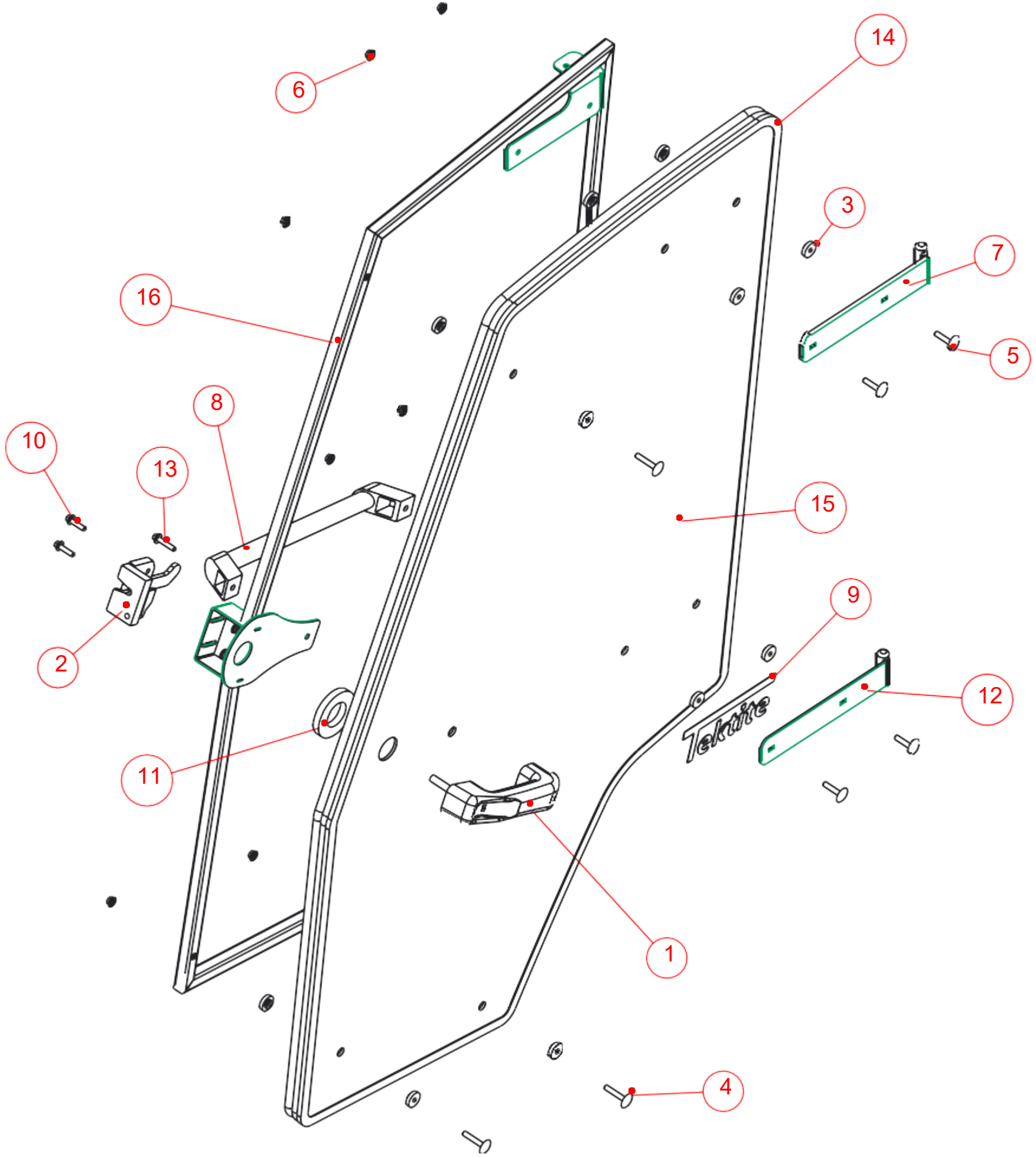

SCALE 0.170  
Notice of Confidentiality

This material is property of Tektite Manufacturing Inc and is not to be used by the recipient for any purpose other than the purpose for which it was transmitted. The material remains the property of Tektite and shall be returned upon request. The material may not be reproduced or disclosed to third parties without the written consent of Tektite.

**Tolerances:**  
Unless otherwise specified  
X.X =  $\pm 1/16"$   
Angular =  $\pm 1.0$

<b>Tektite Manufacturing Inc.</b> 24157 Hwy 3, Box 639, Winkler MB, R6W 4A8, Canada			
Req'd: <b>1 req</b>	CNC:	Description: <b>Door Assembly, 1" Short Cab</b>	
Drawn By: <i>Daryl Furkalo</i>	Date: 2016-06-15	Units: <b>Imp.</b>	File Name: <b>JDX730-ASM-35OP</b>
Checked By:	Date:	Size: <b>B</b>	



Index	Service Part #	File Name	Description	Qty
1	A00-0013	TEKT-0009	5MM Bushing	4
2	A00-0014	TEKT-0092	Thick Bushing	4
3	A00-0020	STEP-BOLT-1-4X1-1-4	Step Bolt, 1/4" x 1 1/4", MB	4
4	A00-0021	FLANGE-NUT-1-4	Flange Nut, 1/4", YD	4
5	J09-0012	JDX730-074V2-	Upper Right Side Window Seal	1
6	J09-0025	JDX730-093	Upper Right Side Front Window, 1" Shorter	1

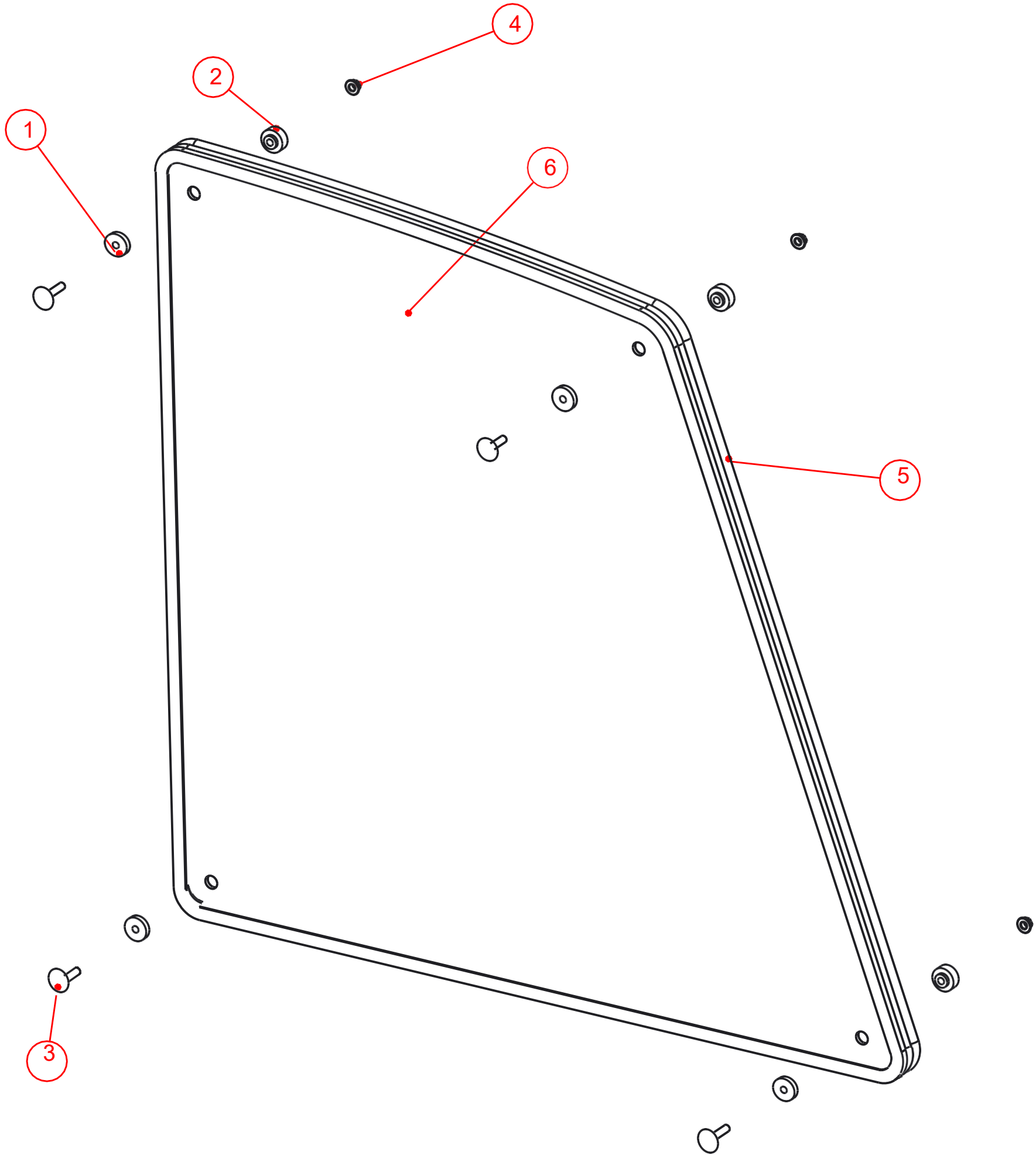

SCALE 0.250

Notice of Confidentiality

This material is property of Tektite Manufacturing Inc and is not to be used by the recipient for any purpose other than the purpose for which it was transmitted. The material remains the property of Tektite and shall be returned upon request. The material may not be reproduced or disclosed to third parties without the written consent of Tektite.

Tolerances:

Unless otherwise specified

X.X =  $\pm 0.0016$ "  
Angular =  $\pm 1.0$

Tektite Manufacturing Inc.

24157 Hwy 3, Box 639, Winkler MB, R6W 4A8, Canada

Req'd: <b>1 cab</b>		CNC:	Description: <b>Upper Right Fixed Window, Short Cab</b>	
Drawn By: <i>Daryl Furkalo</i>	Date: 2016-06-15	Units: <b>Imp.</b>	File Name: <b>JDX730-ASM-37OP</b>	
Checked By:	Date:	Size: <b>B</b>		



Index	Service Part #	File Name	Description	Qty
1	A00-0013	TEKT-0009	5MM Bushing	8
2	A00-0019	STEP-BOLT1-4X1	Step Bolt, 1/4" x 1", MB	4
3	A00-0021	FLANGE-NUT-1-4	Flange Nut, 1/4", YD	4
4	A00-0044	TEKT-ASM-002	Side Window Hinge Weldment	2
5	A00-0045	TEKT-0004	Side Window Slider Bracket, 1" tube	1
6	A00-0057	TEKT-0020MIR	Side Window Latch, L60776	1
7	A00-0058	CARRIAGE_BOLT-5-16X1	Bolt, Carriage, 5/16"x 1", YD	1
8	A00-0059	FLANGE-NUT-5-16	Flange Nut, 5/16", YD	1
9	A00-0119	WASHER_1-4	Washer, Flat, 1/4"	2
10	J09-0008	JDX730-069V2-	Side Window Seal, Short Cab	1
11	J09-0023	JDX730-091	Side Window Glass, Short 1"	1

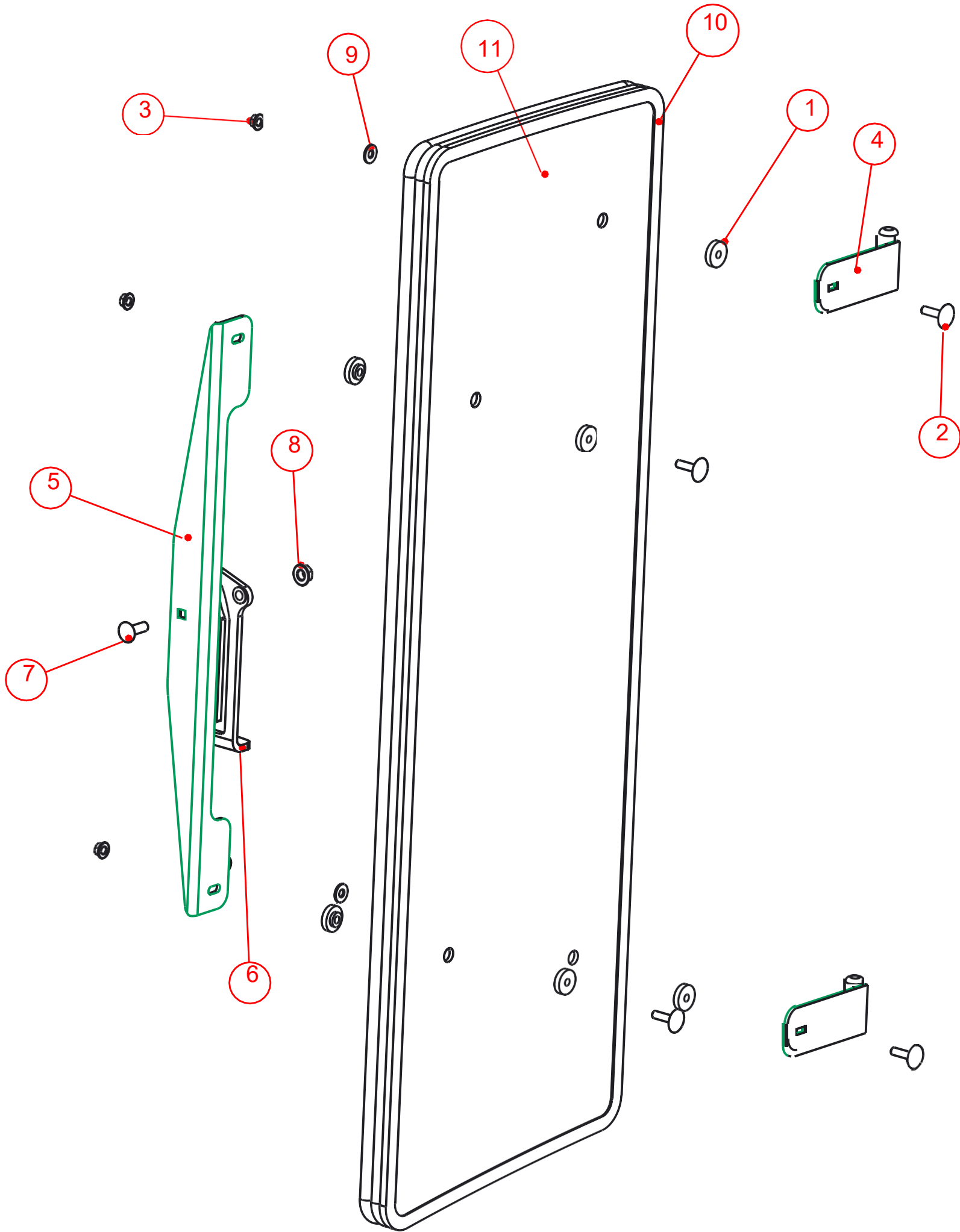

SCALE 0.250  
Notice of Confidentiality

This material is property of Tektite Manufacturing Inc and is not to be used by the recipient for any purpose other than the purpose for which it was transmitted. The material remains the property of Tektite and shall be returned upon request. The material may not be reproduced or disclosed to third parties without the written consent of Tektite.

**Tolerances:**  
Unless otherwise specified  
X.X =  $\pm 1/16"$   
Angular =  $\pm 1.0$

<b>Tektite Manufacturing Inc.</b> 24157 Hwy 3, Box 639, Winkler MB, R6W 4A8, Canada			
Req'd: <b>1 req</b>	CNC:	Description: <b>Left Side Window Assembly, Short Cab</b>	
Drawn By: <i>Daryl Furkalo</i>	Date: 2016-06-15	Units: <b>Imp.</b>	File Name: <b>JDX730-ASM-34OP</b>
Checked By:	Date:	Size: <b>B</b>	





Index	Service Part #	File Name	Description	Qty
1	A00-0013	TEKT-0009	5MM Bushing	8
2	A00-0019	STEP-BOLT1-4X1	Step Bolt, 1/4" x 1", MB	4
3	A00-0021	FLANGE-NUT-1-4	Flange Nut, 1/4", YD	4
4	A00-0045	TEKT-0004	Side Window Slider Bracket, 1" tube	1
5	A00-0046	TEKT-ASM-002R	Side Window Hinge Right	2
6	A00-0056	TEKT-0020	Side Window Latch, L60775	1
7	A00-0058	CARRIAGE_BOLT-5-16X1	Bolt, Carriage, 5/16"x 1", YD	1
8	A00-0059	FLANGE-NUT-5-16	Flange Nut, 5/16", YD	1
9	A00-0119	WASHER_1-4	Washer, Flat, 1/4"	2
10	J09-0008	JDX730-069V2R	Side Window Seal, Short Cab	1
11	J09-0023	JDX730-091	Side Window Glass, Short 1"	1

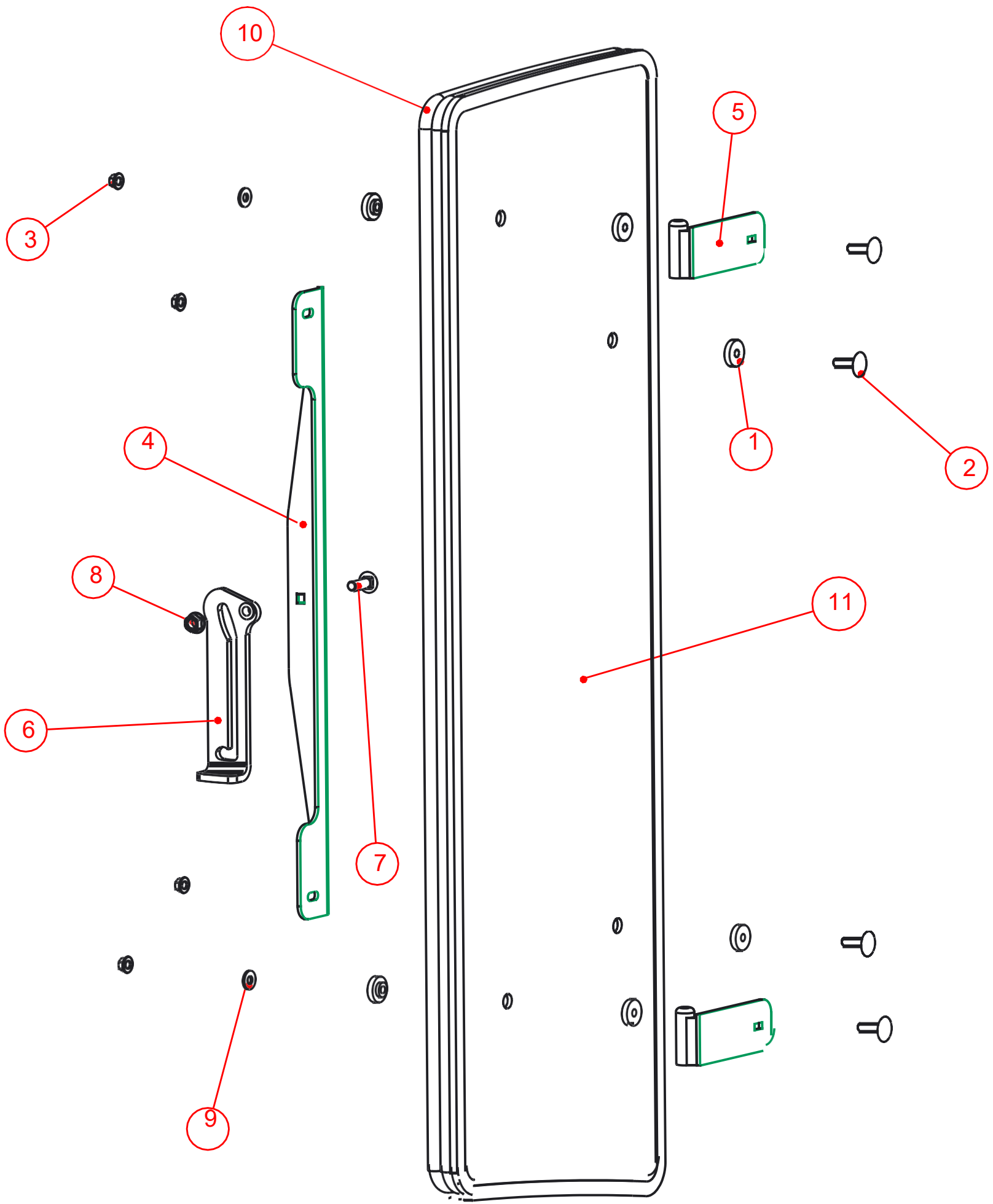

SCALE 0.250  
Notice of Confidentiality

This material is property of Tektite Manufacturing Inc and is not to be used by the recipient for any purpose other than the purpose for which it was transmitted. The material remains the property of Tektite and shall be returned upon request. The material may not be reproduced or disclosed to third parties without the written consent of Tektite.

**Tolerances:**  
Unless otherwise specified  
X.X =  $\pm 1/16$ "  
Angular =  $\pm 1.0$

<b>Tektite Manufacturing Inc.</b> 24157 Hwy 3, Box 639, Winkler MB, R6W 4A8, Canada			
Req'd: <b>1 req</b>	CNC:	Description: <b>Right Side Window Assembly, Short Cab</b>	
Drawn By: <i>Daryl Furkalo</i>	Date: 1 req	Units: <b>Imp.</b>	File Name: <b>JDX730-ASM-34ROP</b>
Checked By:	Date:	Size: <b>B</b>	

Index	Service Part #	File Name	Description	Qty
1	A00-0013	TEKT-0009	5MM Bushing	14
2	A00-0019	STEP-BOLT1-4X1	Step Bolt, 1/4" x 1", MB	3
3	A00-0020	STEP-BOLT1-4X1-1-4	Step Bolt, 1/4" x 1 1/4", MB	4
4	A00-0021	FLANGE-NUT-1-4	Flange Nut, 1/4", YD	7
5	A00-0033	315-080	Rear Wiper Shaft Grommet	1
6	A00-0043	WWF-MOTOR	WWF Wiper Motor, 1" Shaft	1
7	A00-0084	TEKT-0070	Gas Shock	2
8	A00-0085	TEKT-0069	Gas Shock Stud	2
9	A00-0228	TEKT-ASM-029	Left Door Hinge Weldment, Lower	1
10	A00-0229	TEKT-ASM-029R	Right Door Hinge Weldment, Lower	1
11	A00-0285	FLANGE-NUT-NO6	Flange Nut, No 6	4
12	A00-0286	FLANGE_BOLT_NO6X3-8	Flange Bolt, No 6 x 3/8"	4
13	A00-0413	FLANGE-NUT-5-16	Flange Nut, 5/16", YD	2
14	A00-0429	TEKT-ASM-074	WWF, Adjustable Radial Arm, J-Hook, Long	1
15	A00-0430	TEKT-ASM-073	Wiper Blade, 16", J-Hook	1
16	J09-0014	JDX730-075V2-	Windshield Weather Stripping	1
17	J09-0016	JDX730-034	Gas Shock Mount, Front Window	2
18	J09-0022	JDX730-082	Front Window Latch Plate V2	2
19	J09-0026	JDX730-094	Windshield Glass, 1" Shorter	1
20	n/a	LAI1735S-MOUNT-PLATE	Window Latch Mount Plate	2

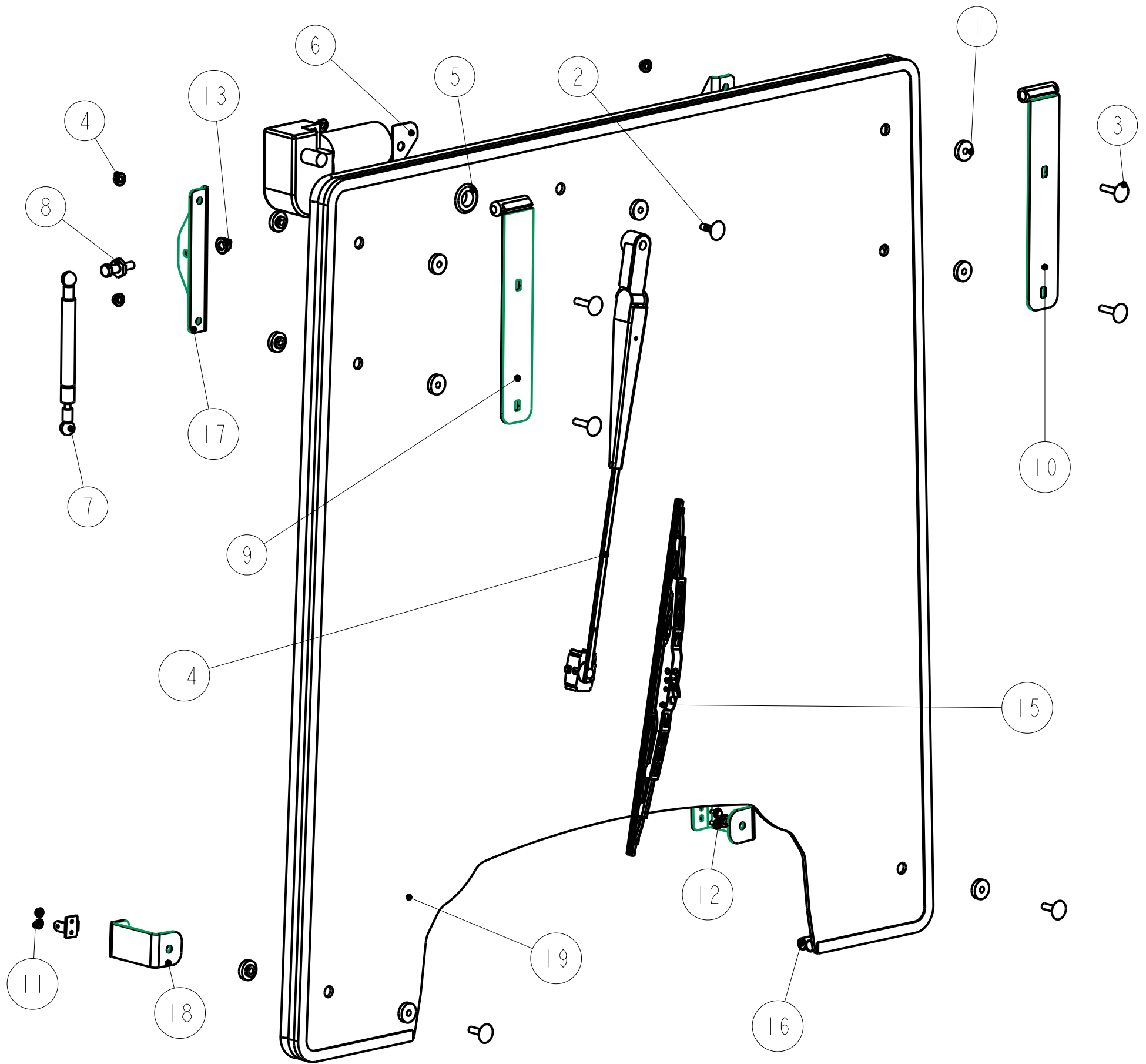

**Tektite Manufacturing Inc.**  
427 Buffalo Str, Box 639, Winkler MB, R6W 4A8, Canada

**Notice of Confidentiality**

This material is property of Tektite Manufacturing Inc and is not to be used by the recipient for any purpose other than the purpose for which it was transmitted. The material remains the property of Tektite and shall be returned upon request. The material may not be reproduced or disclosed to third parties without the written consent of Tektite.

**Tolerances:**  
Unless otherwise specified  
X.X = ±1/16"  
Angular = ± 1.0°

Req'd: <b>1 req</b>	CNC:	Description: <b>Windshield Assembly, Short Cab</b>	
Drawn By: <i>Daryl Furkalo</i>	Date: <b>2025-03-20</b>	Units: <b>Imp.</b>	File Name: <b>JDX730-ASM-38OP</b>
Checked By:	Date:	Size: <b>B</b>	



Index	Service Part #	File Name	Description	Qty
1	A00-0013	TEKT-0009	5MM Bushing	10
2	A00-0014	TEKT-0092	Thick Bushing	5
3	A00-0020	STEP-BOLT1-4X1-1-4	Step Bolt, 1/4" x 1 1/4", MB	5
4	A00-0021	FLANGE-NUT-1-4	Flange Nut, 1/4", YD	5
5	J09-0001	JDX730-060	Lower Right Front Window	1
6	J09-0011	JDX730-073R	Lower Front Right Window Seal	1

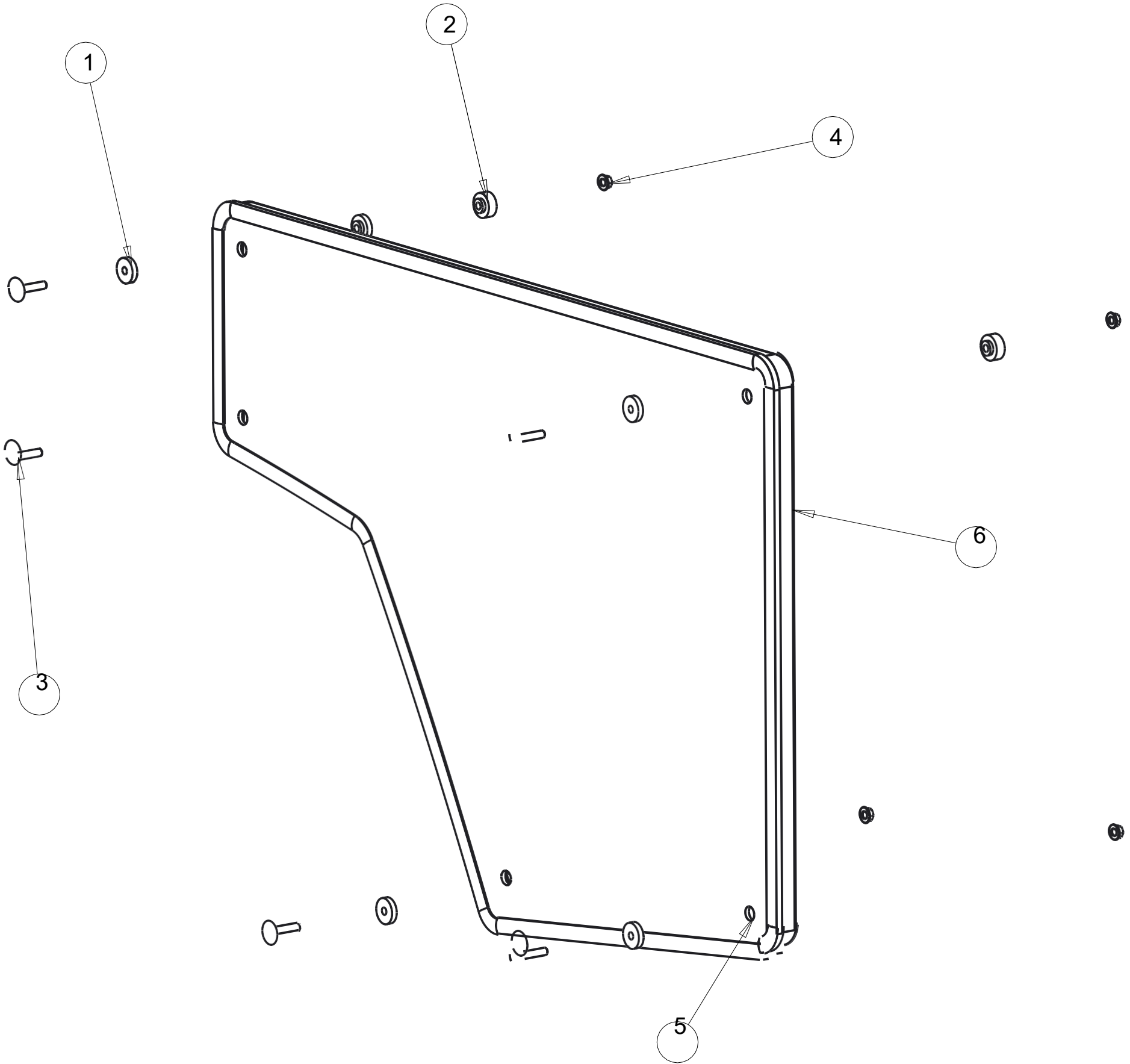

SCALE 0.250

Notice of Confidentiality

This material is property of Tektite Manufacturing Inc and is not to be used by the recipient for any purpose other than the purpose for which it was transmitted. The material remains the property of Tektite and shall be returned upon request. The material may not be reproduced or disclosed to third parties without the written consent of Tektite.

**Tolerances:**  
Unless otherwise specified

X.X = ±.016"  
Angular = 1.0

**Tektite Manufacturing Inc.**

24157 Hwy 3, Box 639, Winkler MB, R6W 4A8, Canada

Req'd:	CNC:	Description: <b>Right Front Lower Window Assembly</b>	
Drawn By: <i>Daryl Furkalo</i>	Date: 2013-11-28	Units: <b>Imp.</b>	File Name: <b>JDX730-ASM-17_OP</b>
Checked By:	Date:	Size: <b>B</b>	



Index	Service Part #	File Name	Description	Qty
1	A00-0013	TEKT-0009	5MM Bushing	6
2	A00-0014	TEKT-0092	Thick Bushing	3
3	A00-0020	STEP-BOLT1-4X1-1-4	Step Bolt, 1/4" x 1 1/4", MB	3
4	A00-0021	FLANGE-NUT-1-4	Flange Nut, 1/4", YD	3
5	J09-0003	JDX730-029	Rear Window Glass	1
6	J09-0010	JDX730-072	Rear Window Weather Stripping	1

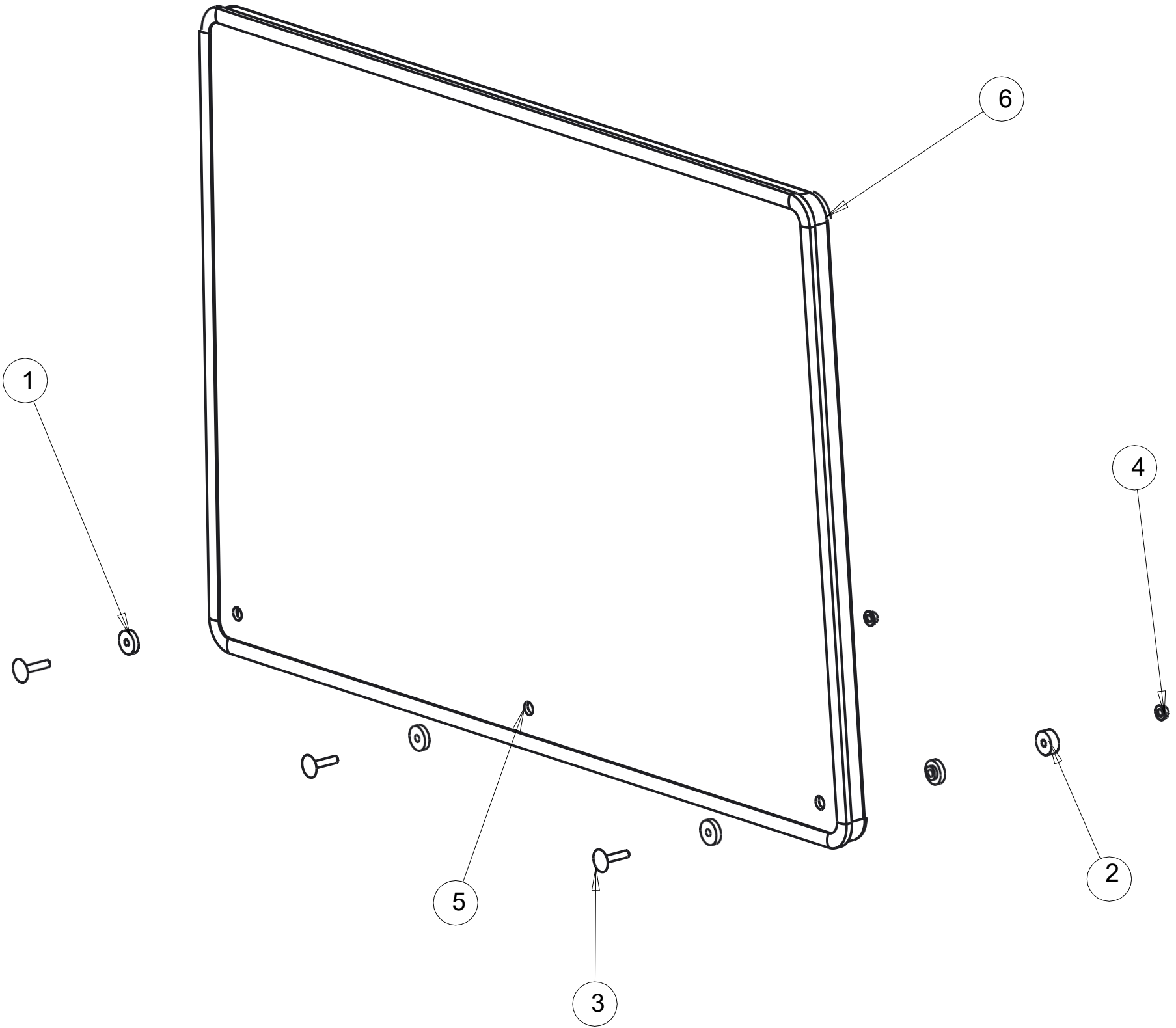

SCALE 0.220  
Notice of Confidentiality

This material is property of Tektite Manufacturing Inc and is not to be used by the recipient for any purpose other than the purpose for which it was transmitted. The material remains the property of Tektite and shall be returned upon request. The material may not be reproduced or disclosed to third parties without the written consent of Tektite.

**Tolerances:**  
Unless otherwise specified  
X.X = ±.016"  
Angular = 1.0

<b>Tektite Manufacturing Inc.</b> 24157 Hwy 3, Box 639, Winkler MB, R6W 4A8, Canada			
Req'd: <b>1 req</b>	CNC:	Description: <b>Rear Window Assembly</b>	
Drawn By: <i>Daryl Furkalo</i>	Date: 2013-11-28	Units: <b>Imp.</b>	File Name: <b>JDX730-ASM-16_OP</b>
Checked By:	Date:	Size: <b>B</b>	

Index	Service Part #	File Name	Description	Qty
1		JDX730-ASM-30		1
2	A00-0023	FLANGE_BOLT_1-4X3-4	Flange Bolt, 1/4" x 3/4", YD	2
3	A00-0061	TEKT-0021	Striker Mounting Plate	1
4	A00-0084	TEKT-0070	Gas Shock	1
5	A00-0085	TEKT-0069	Gas Shock Stud	1
6	A00-0101	STRIKER-PIN	Striker Pin	1
7	A00-0103	HEX-NUT-MI2X1	Hex Nut, M12 x 1.0, YD	1
8	A00-0131	TEKT-0181	External Fuel Cap	1
9	A00-0285	FLANGE-NUT-NO6	Flange Nut, No 6	4
10	A00-0286	FLANGE_BOLT_NO6X3-8	Flange Bolt, No 6 x 3/8"	4
11	A00-0371	TEKT-0175	New LED Work Light (Blazer Intl)	4
12	A00-0389	KUBX2380-NOSTRIL	Plastic Light Nostril	2
13	A00-0413	FLANGE-NUT-5-16	Flange Nut, 5/16", YD	1
14	A00-0519	TEKT-0244	Rectangular Mirror	2
15	A00-0520	TEKT-0243	Mirror Bracket Bar	2
16	A00-0521	MI2X1.75-NYLOCK-NUT	Nylon Lock Nut, M12 x 1.75	3
17	A00-0535	TEKT-0249	Rectangular Interior Mirror	1
18	A00-0536	TEKT-0250	Spacer For Interior Mirror	1
19	A00-0537	CARRIAGE_BOLT_M12X50	Carriage Bolt, M12 x 50	1
20	A00-0552	MI2X1.75-LOCK-NUT	M12 x 1.75 Crimp Lock Nut	2
21	J09-0030	JDX730-109	Wide Flap Rubber Seal	1
22	J09-0030	JDX730-109R	Wide Flap Rubber Seal	1
23	J09-0034	LAI1735M-KEEPER	Window Latch Keeper Mount, Medium	2

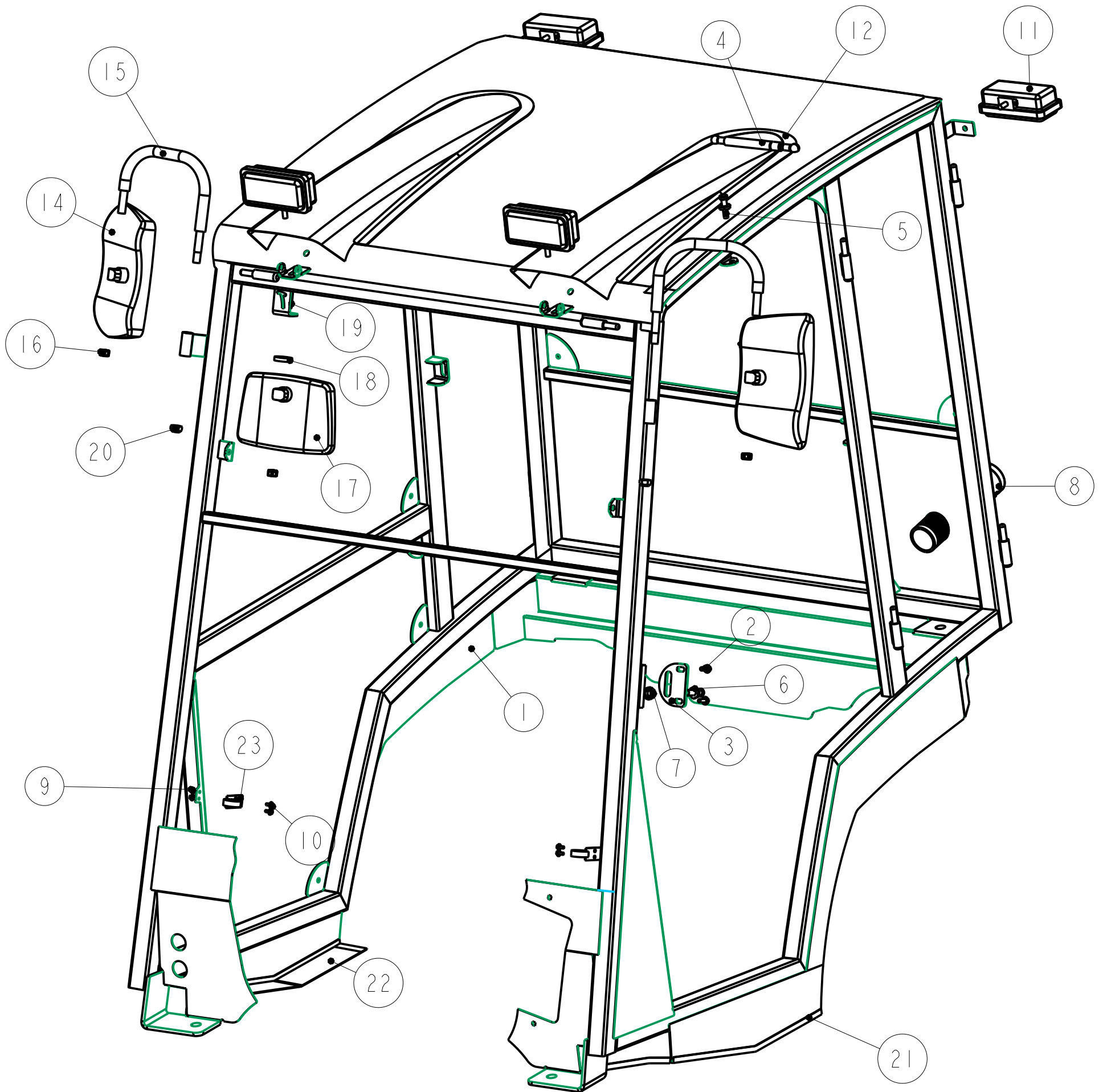

**Tektite Manufacturing Inc.**  
427 Buffalo Str, Box 639, Winkler MB, R6W 4A8, Canada

**Notice of Confidentiality**

This material is property of Tektite Manufacturing Inc and is not to be used by the recipient for any purpose other than the purpose for which it was transmitted. The material remains the property of Tektite and shall be returned upon request. The material may not be reproduced or disclosed to third parties without the written consent of Tektite.

**Tolerances:**  
Unless otherwise specified  
X.X = ±1/16"  
Angular = ± 1.0°

Req'd: <b>1 req</b>	CNC:	Description: <b>Assembly Accessories</b>	
Drawn By: <b>Daryl Furkalo</b>	Date: <b>2025-03-20</b>	Units: <b>Imp.</b>	File Name: <b>JDX730-ASM-41</b>
Checked By:	Date:	Size: <b>B</b>	

Index	Service Part #	File Name	Description	Qty
1	A00-0024	BUSS-15600-08-11	Power Block/Ground	1
2	A00-0065	TEKT-ASM-005	On-Off Switch w/Lens	8
3	A00-0180	BOLT_10-32X1	Fuse Block Bolts	2
4	A00-0181	HEX-NUT-10-32	Fuse Block Nuts	2
5	A00-0218	TEKT-0218	10-24 Panel Nut	4
6	A00-0354	SCREW-10-24X3-4	Screw, 10-24 x 3/4",MB	6
7	A00-0418	TEKT-0010	Fuse Block Retainer Bracket	1
8	A00-0494	TEKT-0221	10-24 Panel Nut, Thick	2
9	A00-0531	TEKT-ASM-086	2023 Fuse Cover, Magnet Assembly	1
10	A00-0539	TEKT-0248	Switch Plate, V5 ST	1
11	n/a	TEKT-0247	Switchplate Mount V7	1

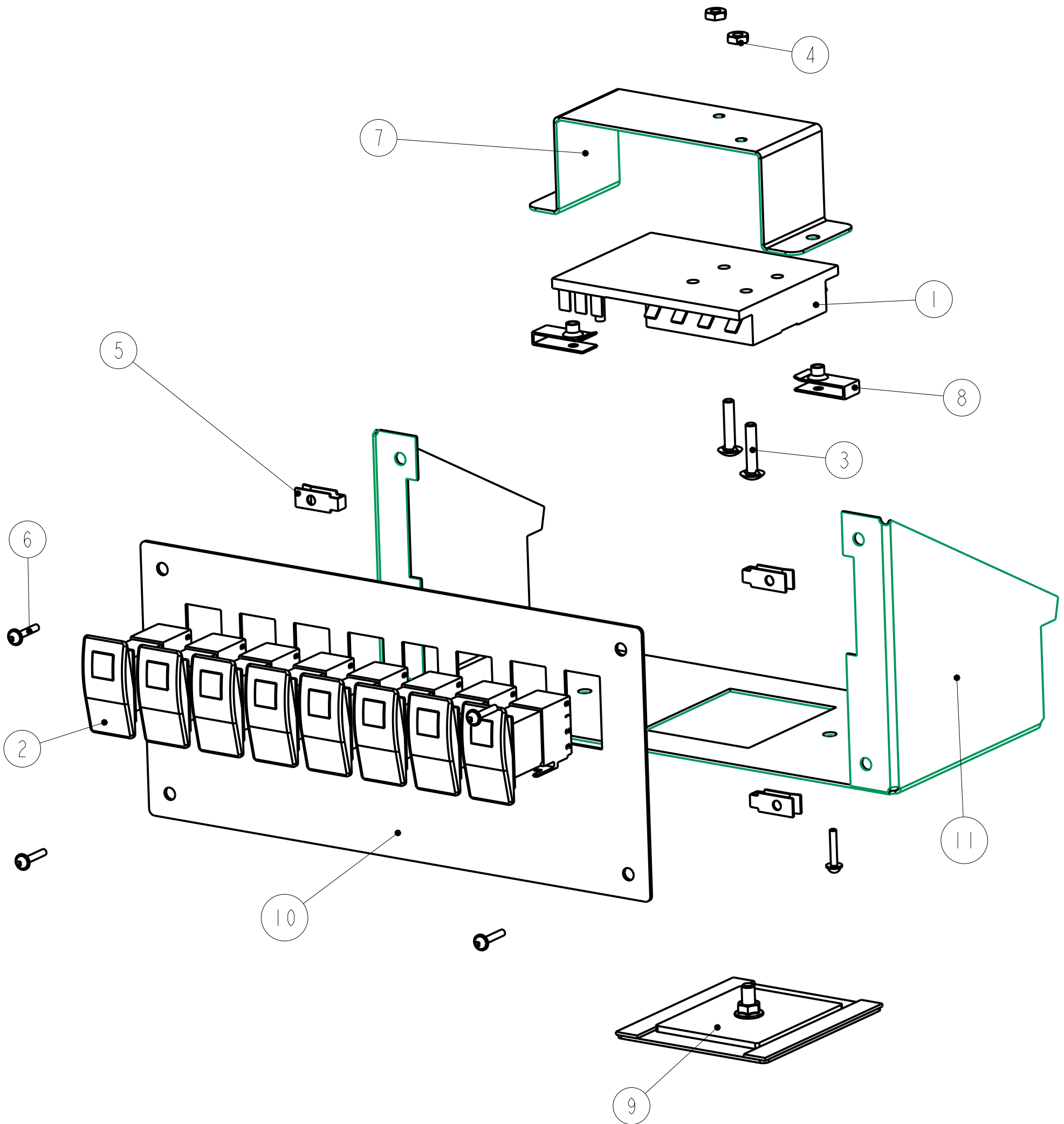

**Tektite Manufacturing Inc.**  
427 Buffalo Str, Box 639, Winkler MB, R6W 4A8, Canada

**Notice of Confidentiality**

This material is property of Tektite Manufacturing Inc and is not to be used by the recipient for any purpose other than the purpose for which it was transmitted. The material remains the property of Tektite and shall be returned upon request. The material may not be reproduced or disclosed to third parties without the written consent of Tektite.

**Tolerances:**  
Unless otherwise specified  
X.X =  $\pm 1/16"$   
Angular =  $\pm 1.0^\circ$

Req'd: <b>1 req</b>	CNC:	Description: <b>2023 Steel Top Fuse Block Assembly</b>	
Drawn By: <i>Daryl Furkalo</i>	Date: <b>2023-06-02</b>	Units: <b>Imp.</b>	File Name: <b>TEKT-ASM-088_OP</b>
Checked By:	Date:	Size: <b>B</b>	