

## John Deere 1600 Turbo WAM Series 3 ROPS Cab



\*\*Shown with optional equipment

### John Deere JD1600S3-001 1600T WAM Series 3 ROPS Cab

This ROPS cab is designed and built to fit:  
John Deere 1600 Turbo WAM Series 3.

Designed and built by:

**Tektite Manufacturing Inc:**  
P.O. Box 639, 427 Buffalo Street  
Winkler, MB, Canada  
R6W 4A8  
PH: 204-331-3463  
[parts@tektite.ca](mailto:parts@tektite.ca)

One-year standard product warranty provided by Tektite Manufacturing Inc.  
[www.tektite.ca](http://www.tektite.ca) / [www.tektitecabs.com](http://www.tektitecabs.com)



**DO NOT PROCEED FURTHER UNTIL YOU HAVE READ THE INFORMATION BELOW.**

- 1) Always wear personal protective equipment.
- 2) A minimum of two people is necessary to safely install the cab.
- 3) This ROPS cab is heavy. A lift assist device such as an overhead hoist or high lift forklift is required.
- 4) Ensure your work area is well ventilated. The installation requires the starting of the tractor which will produce dangerous carbon monoxide fumes.
- 5) Read through the entire installation manual first.
- 6) Follow the installation instructions in order.
- 7) Reading the operators manual prior to using the ROPS cab.

Tektite Manufacturing Incorporated thanks you for purchasing a John Deere 1600T WAM Series 3 ROPS cab! Tektite has worked very hard to design and build this ROPS product and we hope that it provides you with many years of protection.

Tektite's products are designed to provide safe and dependable service during operation when they are properly maintained according to the instructions. Please read this installation manual carefully before installing and using this product.

The photos/illustrations provided in this manual may not provide all the detail needed and are for reference only.

All directions provided are from the reference point of the tractor seat facing the steering wheel. All left and right references are from this viewpoint.

For reference, please fill in the information below. This will assist your dealer in providing service for this product. It is advisable that this information be provided to your insurance company as well in the event that the tractor is lost or damaged.

Vehicle Model: \_\_\_\_\_

Tektite Serial Number: \_\_\_\_\_

Date of Purchase: \_\_\_\_\_

Dealer Name: \_\_\_\_\_

**Parts List Standard Cab:****Mounting Parts Bag:**

<b>Description</b>	<b>Qty</b>
Bolt, Hex, 5/8" x 3", Gr. 8, YD	4
Flat Structural Washer, 1/4" thick	4
Nut, Flange, 5/16"	2
Bolt, Flange, 5/16" x 1 1/2"	2
Nut, Flange, 5/8", Gr. 8, YD	4
Bolt, Flange, M12 x 35 x 1.75, Gr. 10.9, YD	3
Nut, Flange, M12 x 1.75, Gr. 10.9, YD	1
Bolt, Hex, 1/2" x 4 1/2", Gr. 8	2
Shrink Wrap for Wire	1"
Wire Loop Yellow, 1/4"	2
Wire Loop Yellow, 3/8"	2
Zip Ties, Standard	4

**Loose Components:**

<b>Description</b>	<b>Qty</b>
Rear Cab Mounting Brackets	L&R
Front Cab Mounting Brackets	L&R
Chassis Isolator, Rubber, 5/8" (pre-install)	4
Step Extension Bracket	1
Left Under Fuel Tank Shield	1
Floormat, operator platform	1
Cab Lift Brackets	2
Fuel Hose Elbow	1

**Parts List Optional Components:****Heater**

Description	Qty
Straight fitting, 3/8NPT x 3/8" barb	2
HS-6 hose clamps	2
3/8" ID heater hose	21' Long

**Air Conditioning**

Description	Qty.
Compressor, <b>Rear Port</b>	1
Muffler Extension Pipe	1
Muffler Support Bracket	1
Compressor Tensioner Bracket	1
Alternator Tensioner Bracket	1
V-Belt, 13/32" x 24 5/8"	1
Muffler Clamps, 2"	2
Fan Spacer Plate, 1/2" THICK	1
Tube Spacer, Sked 80, 11/16" OD x 13/32" ID, <b>11/16"</b> Long, CRITICAL	2
Tube Spacer, Sked 80, 11/16" OD x 13/32" ID, <b>1/2"</b> Long, CRITICAL	1
Tube Spacer, Sked 80, 11/16" OD x 13/32" ID, <b>1/4"</b> Short, CRITICAL	1
Bolt, Flange, 3/8" x 1 1/2"	2
Nut, Flange, 3/8"	5
Bolt, Hex, 3/8" x 4", Gr. 8	1
Bolt, Flange, M6 x 40, YD, Gr. 10.9	4
Bolt, Hex, 3/8" x 1"	2
Zip Ties, Standard	4
Female Bullet, Blue	1

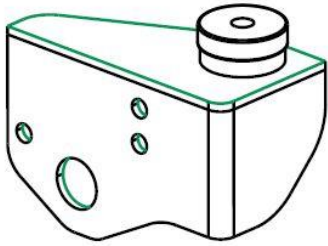

Left Front Bracket

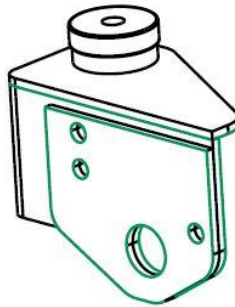

Right Front Bracket



Right Rear Bracket

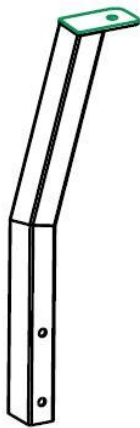

Left Rear Bracket



Step Extension Bracket

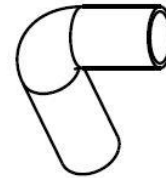

Fuel Hose, Elbow



Left Fuel Tank Seal Bracket

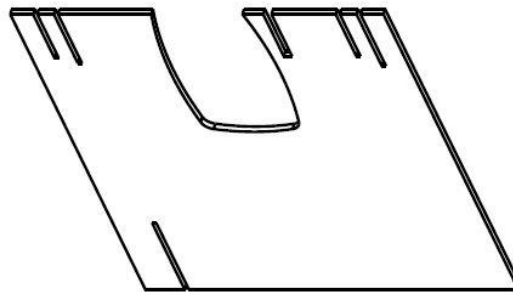

Main Cab Floor Mat

*Air Conditioning  
Loose Parts Only*



Alternator  
Spacers  
11/16" TWO



Tube  
Spacer  
1/4"  
Length  
Short



Tube  
Spacer  
1/2"  
Length  
Long

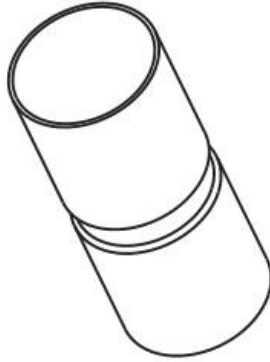

Muffler  
Extension

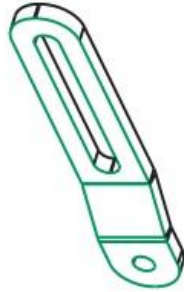

Compressor  
Tensioner  
Bracket



Muffler  
Retainer  
Bracket

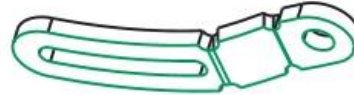

Alternator  
Tensioner  
Bracket



*If heater and air conditioner option has been ordered, compressor installation can be done independent of cab install. Park machine in well-ventilated room with hoist or fork lift access. Drop front and side wing decks.*

**Optional Heater Installation Instructions:**

- Drain engine coolant.
- Locate plug on right side of engine as shown below.

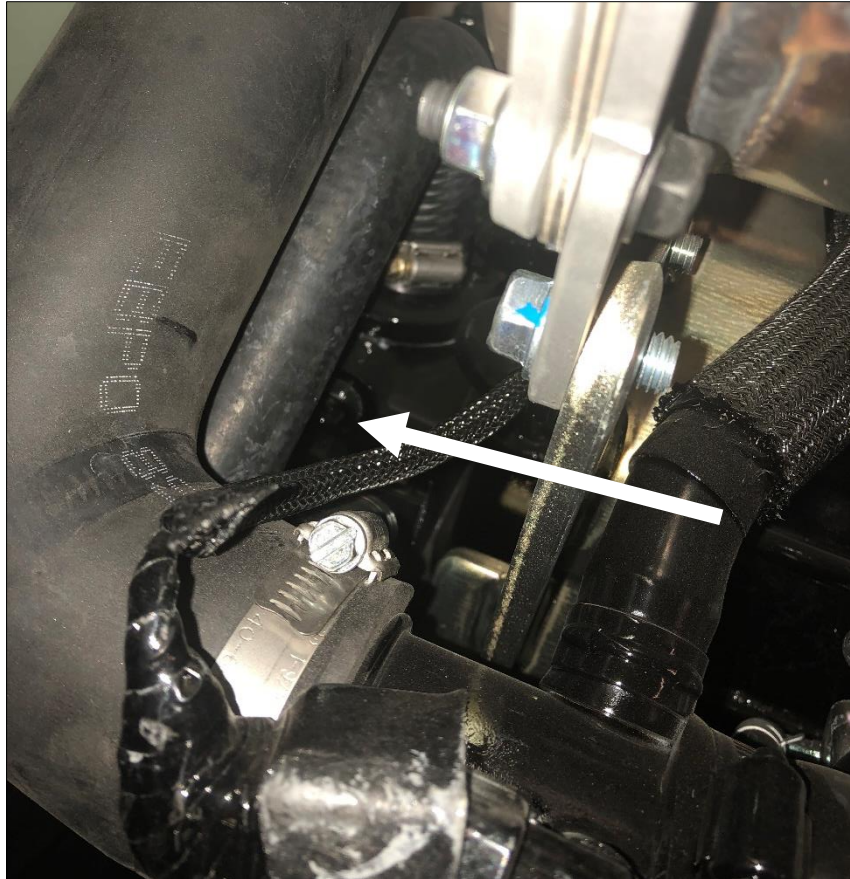

- Remove the plug. Take the provided 3/8NPT x 3/8" barb straight fitting, put Teflon tape on the threads, and then install into open port on the engine.



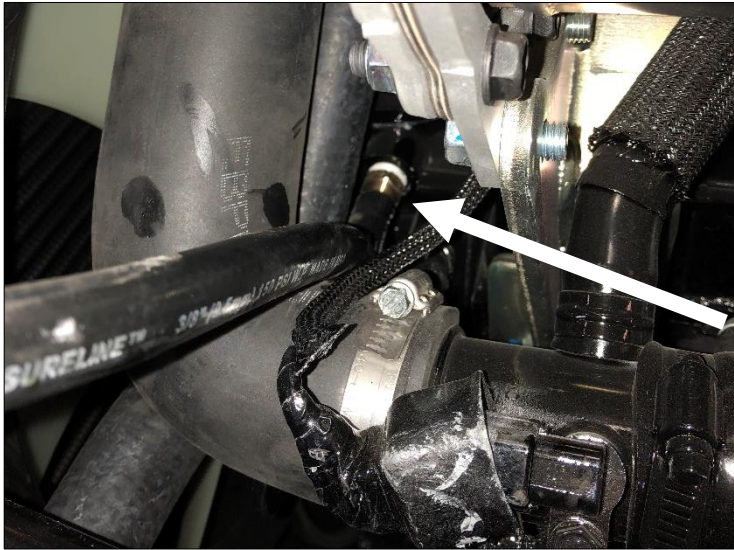

Pressure

- Locate plug on left side of engine as shown below.

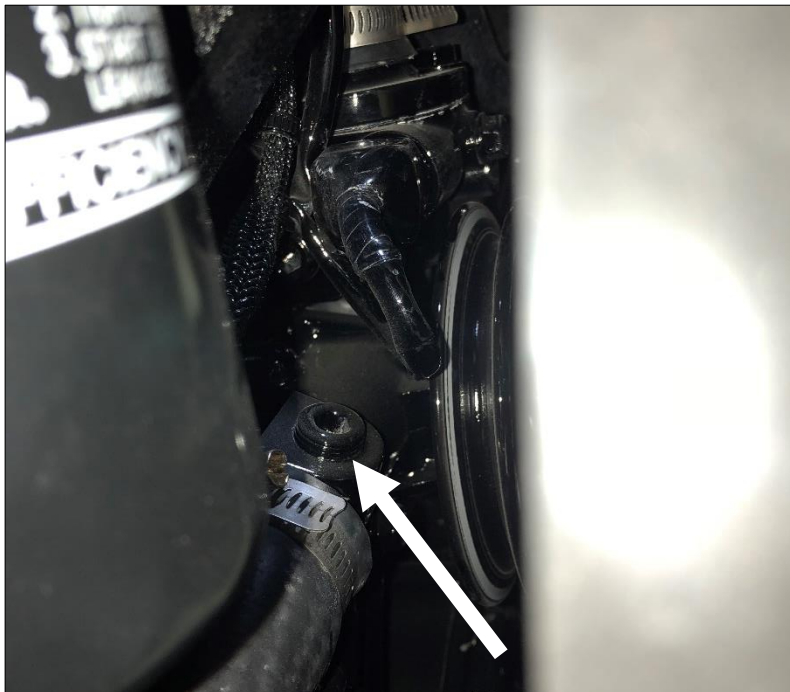

- Remove the plug. Take the provided 3/8NPT x 3/8" barb straight fitting, put Teflon tape on the threads, and then install into open port on the engine.

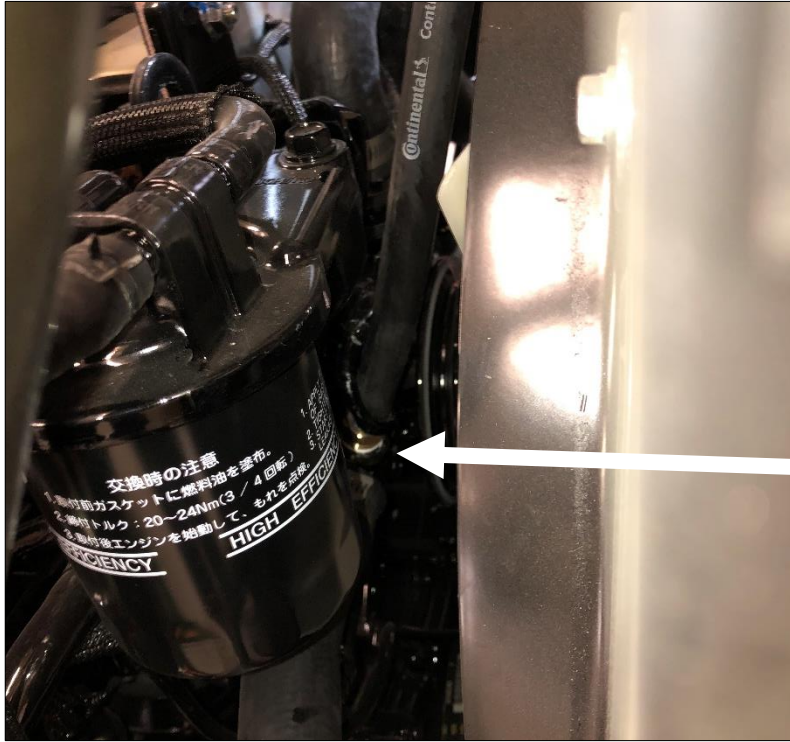

Suction

**Optional Air Conditioner Installation Instructions:**

- Disconnect the battery.
- Disconnect the alternator harness plug from the back of the alternator.
- Un-bolt the two exhaust U-bolts with clamps and remove.
- Remove the four fasteners attaching the tail pipe to the muffler. Pull the tail pipe off the end of the muffler.
- Un-bolt and remove the alternator tensioner to remove belt tension. Then un-bolt and remove the alternator.
- Locate the radiator shroud access panel and pull up to remove.

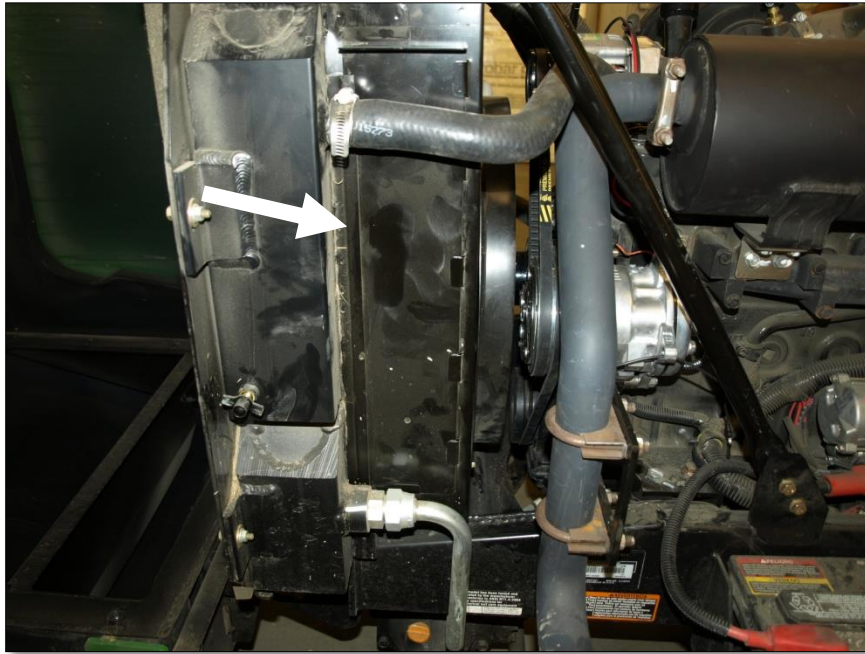

- Using the access provided with the removal of the radiator shroud access panel, un-bolt the main fan pulley, secured with four M6 x 30 fasteners.
- Take the provided ½" fan spacer plate and install it between the outside fan spacer and the fan pulley, ensure the grooves fit in properly. Use the provided M6 x 40 flange bolts and re-fasten fan pulley.
- Locate the air diverter shield and remove the two fasteners and remove shield.

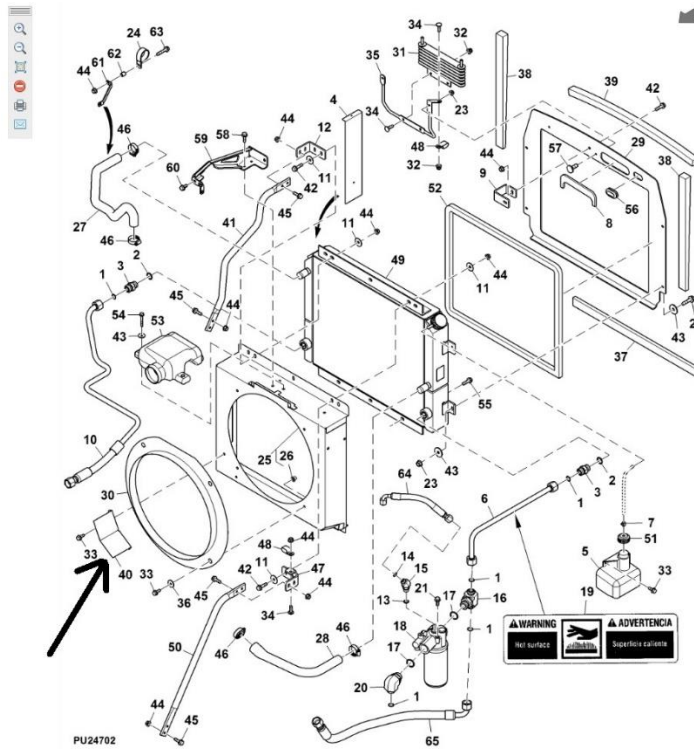

- Mark 2" inches in each direction as shown below and remove material from the air diverter shield with a bandsaw.

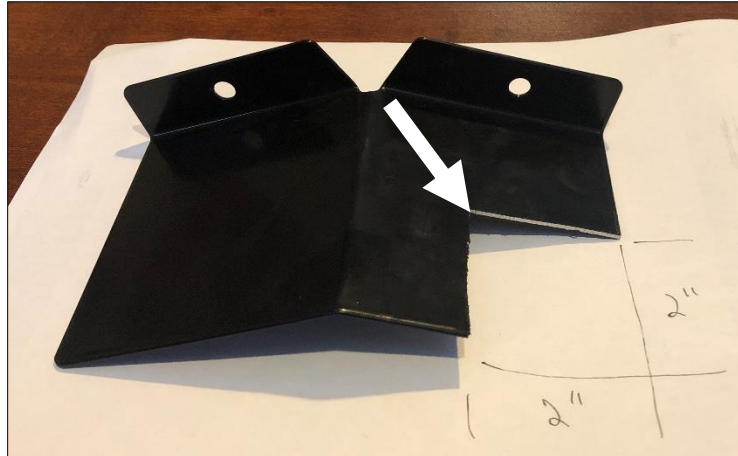

- Re-install the air diverter shield with the factory hardware.

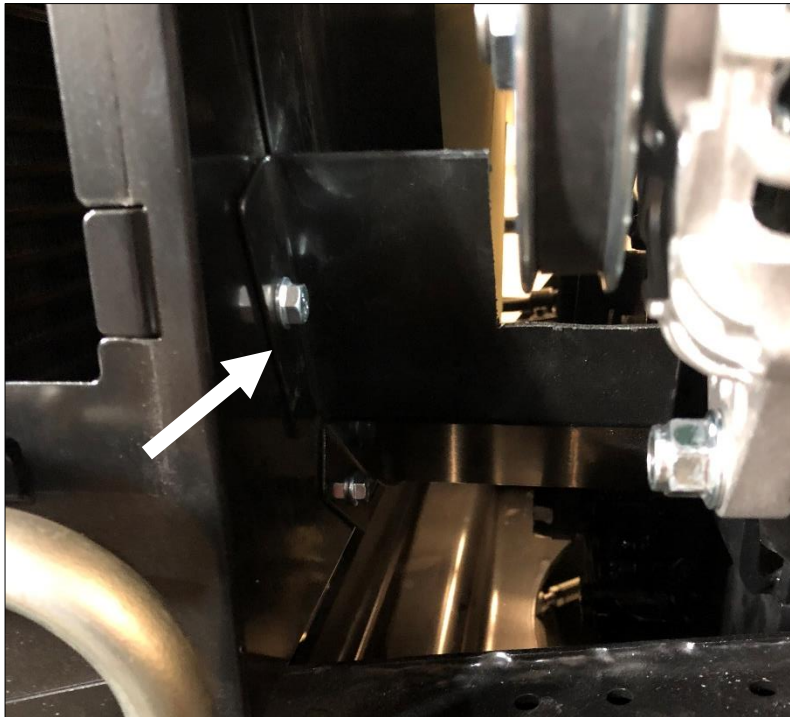

- Follow schematic for proper bolt alignment procedure. Locate the two tube spacers,  $\frac{1}{4}$ " and  $\frac{1}{2}$ ",  $\frac{3}{8}$ " flange nut, and  $\frac{3}{8}$ " x 4" hex bolt. The bolt SHOULD be started from the front and go through the compressor flange, long spacer, engine block, short spacer, compressor flange, and then into the flange nut.



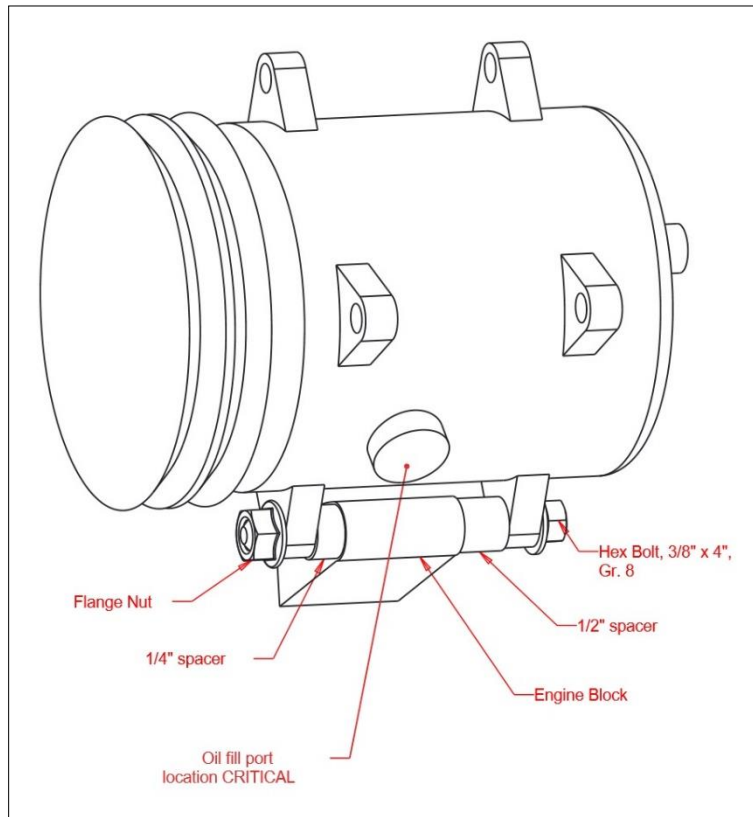

- Slip the main drive belt around the inner pulley on the compressor, around the fan pulley and main drive pulley below.
- Take the provided compressor tensioner plate and fasten to factory location with factory hardware. Apply belt tension on the compressor belt loop and tighten 3/8" compressor mount fastener first, then tighten the tensioner bracket next. Use provided 3/8" x 1 1/2" flange bolt and nut for tensioner fastener on compressor.
- Locate the engine mount plate shown below. It is necessary to remove some material to provide space for the alternator. Remove 1/4" off the top of the plate as shown below just above the inner most slot.
- Use black touch up paint in area after complete.

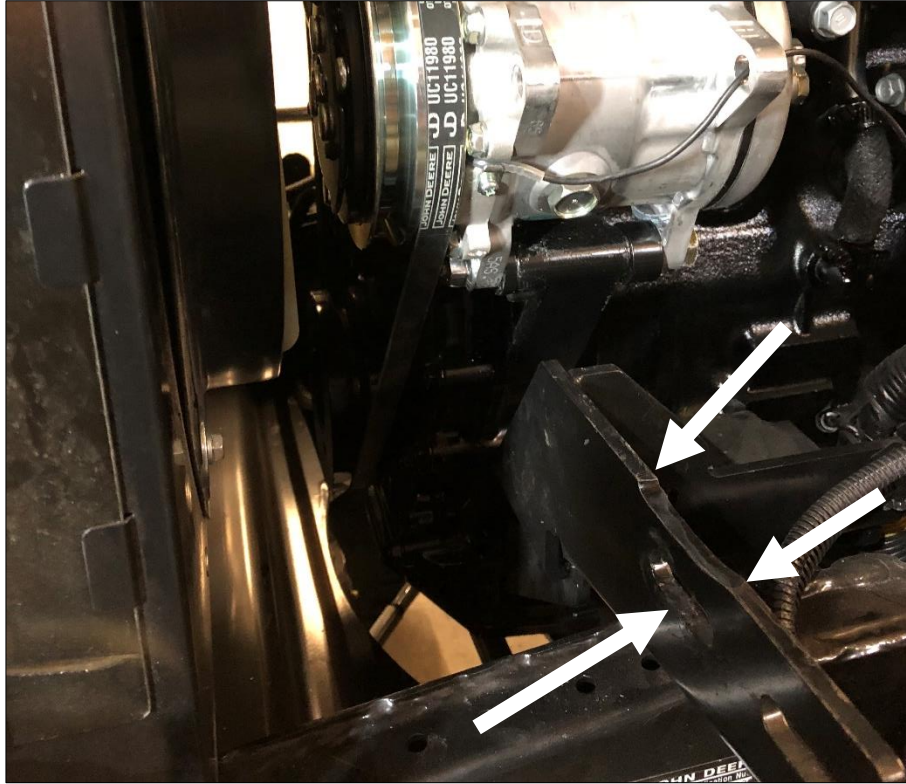

- Take the alternator along with the provided two 11/16" spacers. Position alternator as far inside of slot as possible and use factory hardware with provided spacers on each side of mount plate as shown to fasten into place.



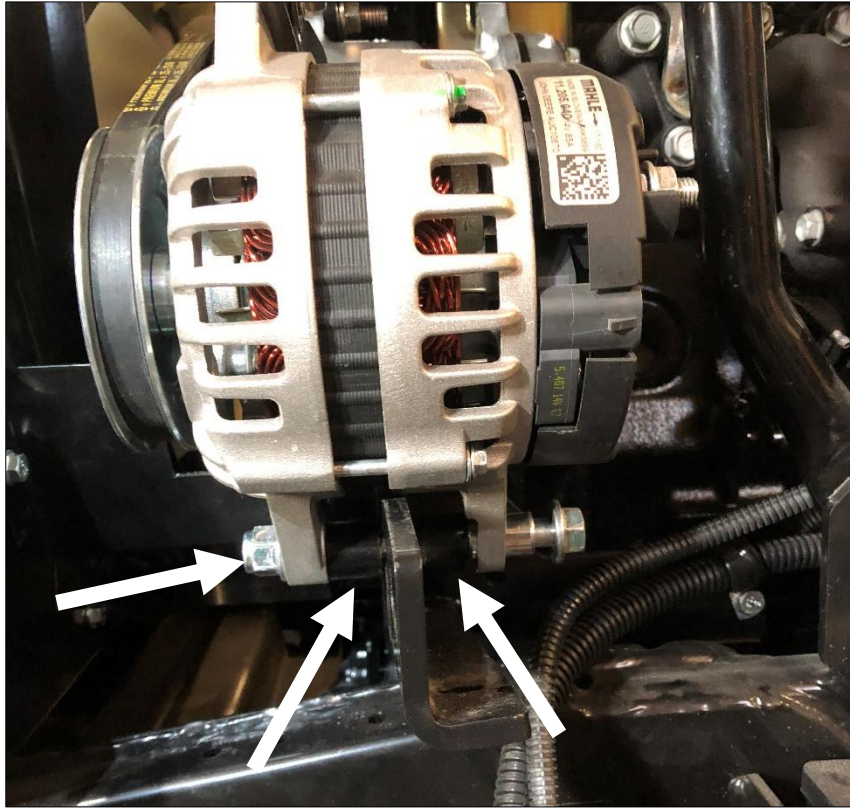

- Take the alternator tensioner and fasten to the compressor with the provided 3/8" x 1 1/2" flange bolt and nut.

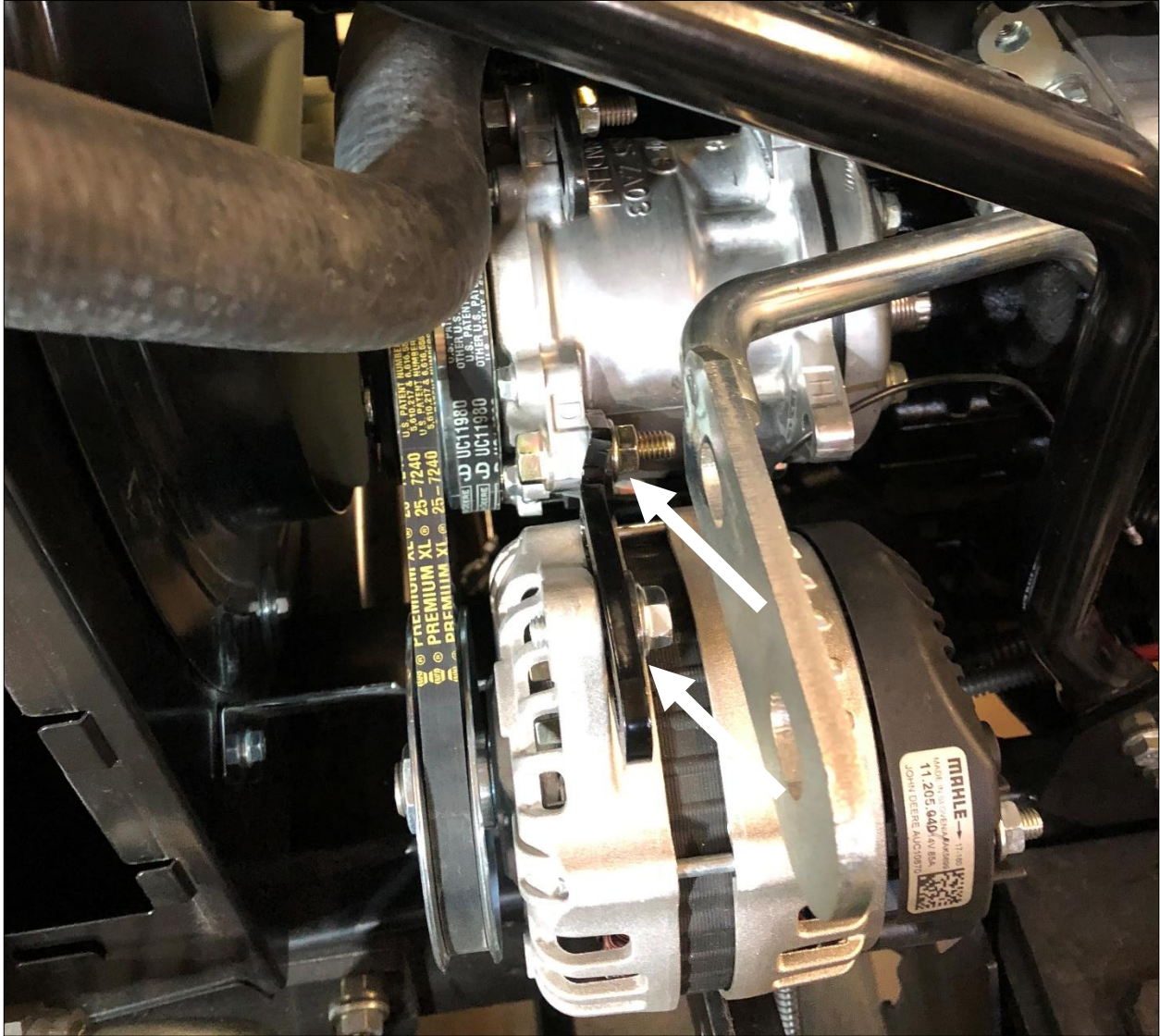

- Slip the shorter alternator drive belt around the outer compressor pulley and the alternator.
- Apply tension to alternator. Use factory bolt for alternator tensioner bracket.
- Take the tail pipe and cut 3 ½" from the elbow as shown below.

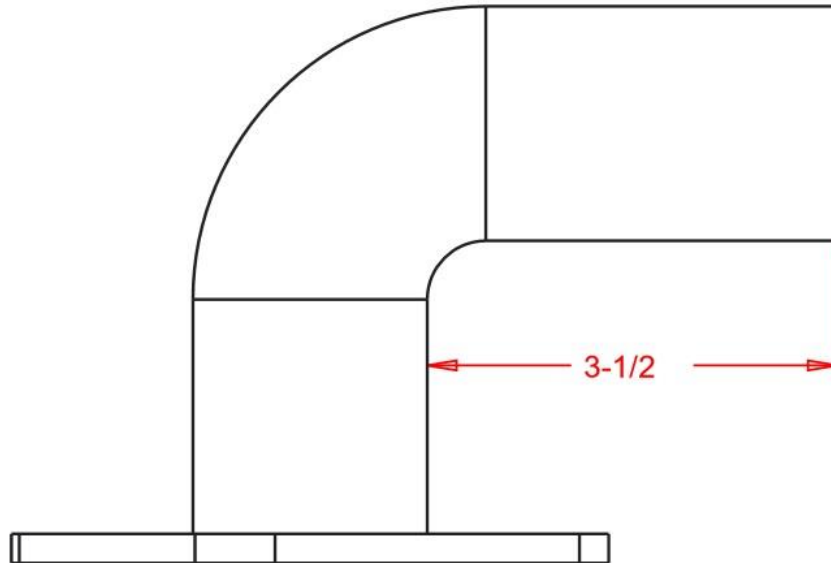

- Re-install the muffler end plate on to muffler with factory hardware.

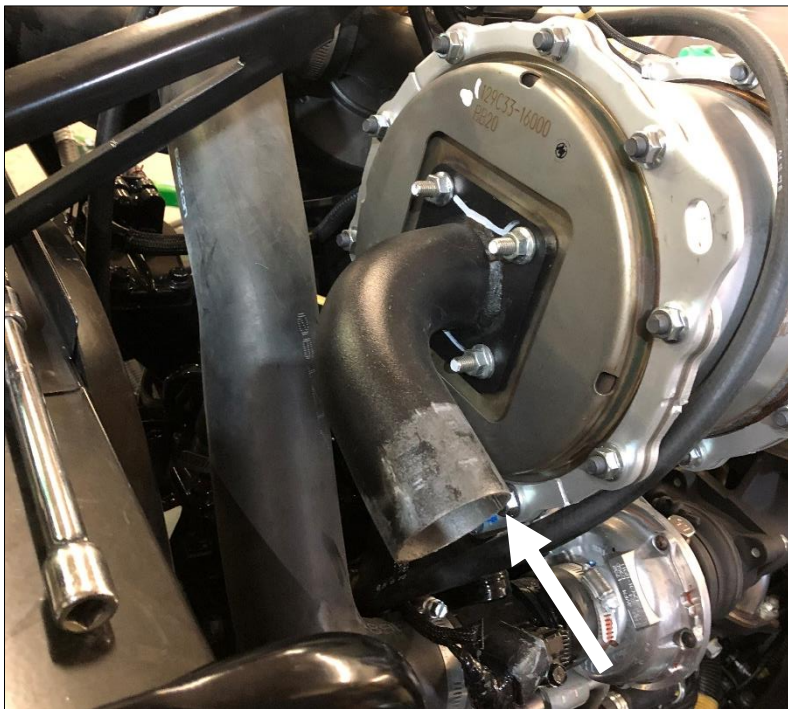

- Take the provided muffler extension and one of the muffler clamps provided and slip onto tail pipe installed on engine. Loosely clamp into position.
- Take the cut off tail pipe and remaining muffler clamp. Slide onto end of muffler extension. Loosely clamp.



- Take the provided tail pipe retainer bracket, along with 3/8" x 1" hex bolts and flange nuts. Fasten one side to the original mount bracket with provided 3/8" x 1" bolts and nuts. Use one of the factory hose clamps for the second location. Tighten into place.

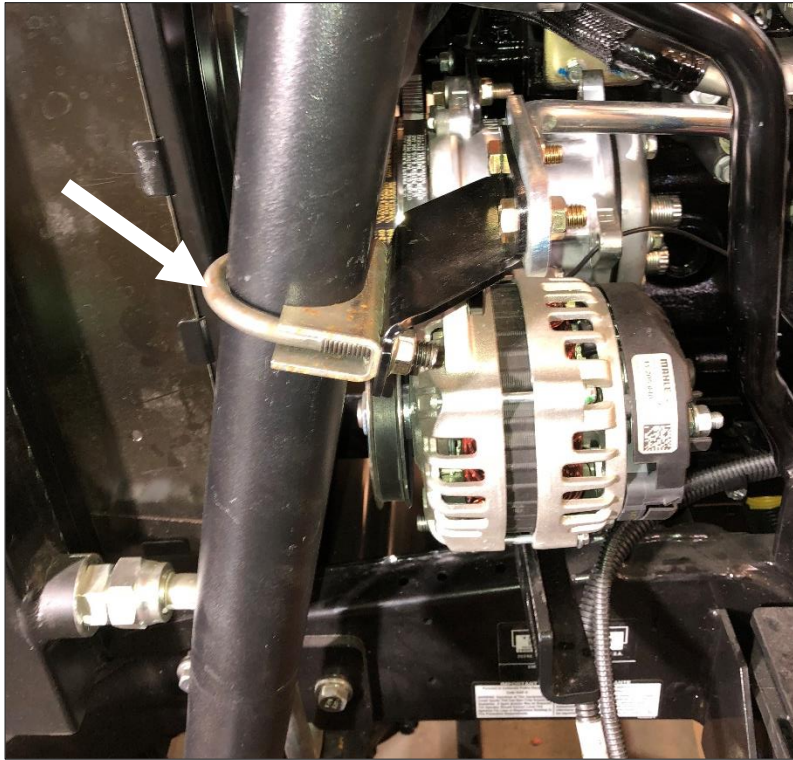

- Tighten top two hose clamps now.
- Re-connect wires onto the alternator.
- Re-install the radiator access shroud access panel removed earlier.

*The balance of heater and air conditioner installation can only be completed after the cab is installed. Please proceed with cab installation.*

**Installation Instructions:**

- . Un-bolt and remove the shield between the lower 2-post ROPS sockets fastened to the front of the hood.
- . Un-bolt and remove the left and right 2-post ROPS socket shields.
- . Un-bolt and remove the 2-post ROPS assembly. It will be necessary to raise the wing deck on the side you are removing fasteners from in order to get adequate access to the mounting bolts.
- . Take the left under fuel tank shield and proceed to the left side of the operator platform. Locate the outer right flange bolt on the vertical face of the seat platform and remove. Take the shield and slide into position underneath the fuel tank and against the seat box and side fender, fit will be snug. Re-use fastener removed earlier and bolt into place.



- . Take the left rear bracket and slide into the left 2-post ROPS socket and fasten with the factory hardware. Loosely attach only.

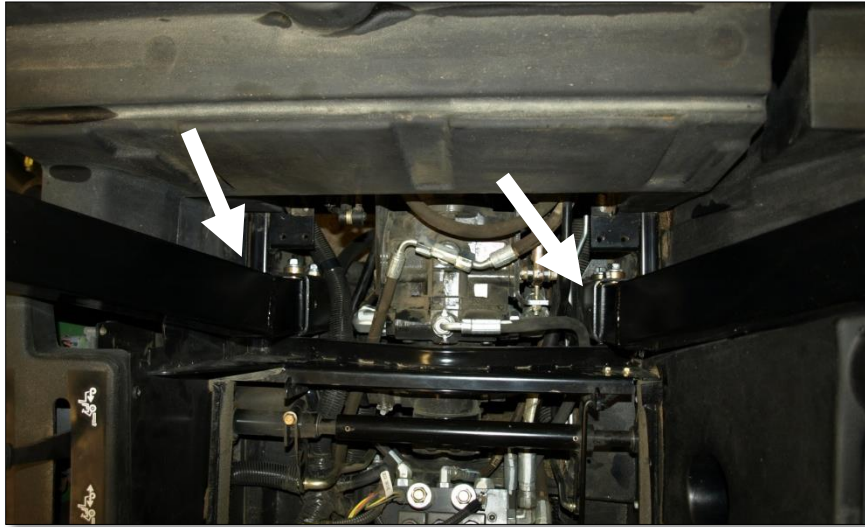

. Take the right rear bracket and slide into the right 2-post ROPS socket and fasten with the factory hardware. Loosely attach only.

. Take the right front bracket and fasten to the front operator platform as shown below. Use the provided M12 x 35 flange bolts for the front fasteners and flange bolt and nut for the rear fastener.

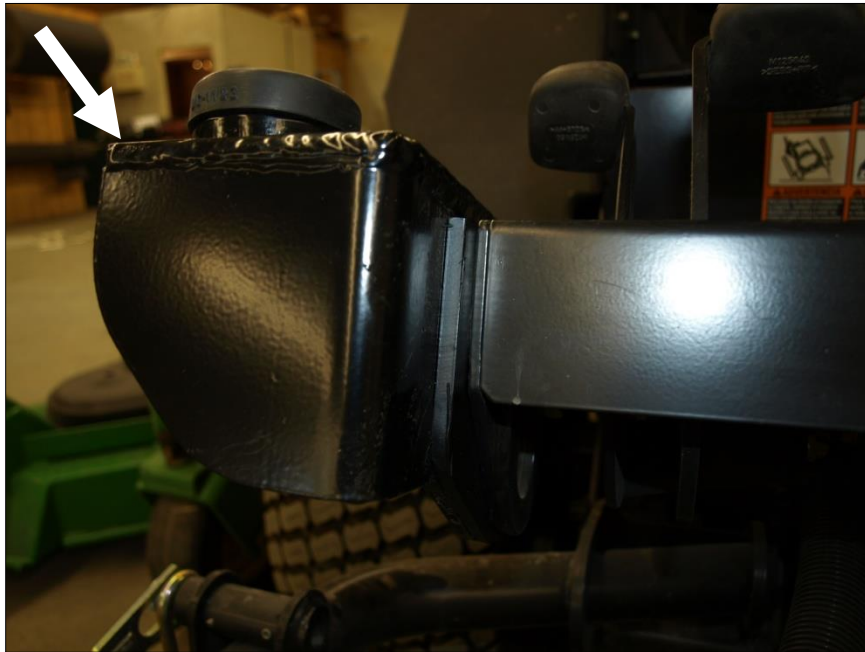

. Un-bolt the front deck stop bracket on left front of operator foot platform and place the left front bracket outside of it. Use the existing factory hardware and bolt into place.





- . Un-bolt the step plate located on the front deck.
- . Take the provided step extension bracket and fasten into place where step used to mount onto the front deck with the factory original fasteners.
- . Take the two provided 5/16" x 1 1/2" flange bolts and nuts and fasten the step plate to the extension bracket plate.



Original  
Fasteners



. Un-bolt and remove the outer left brake pedal from the from the mount underneath the operator platform, M8 x 25 fasteners.

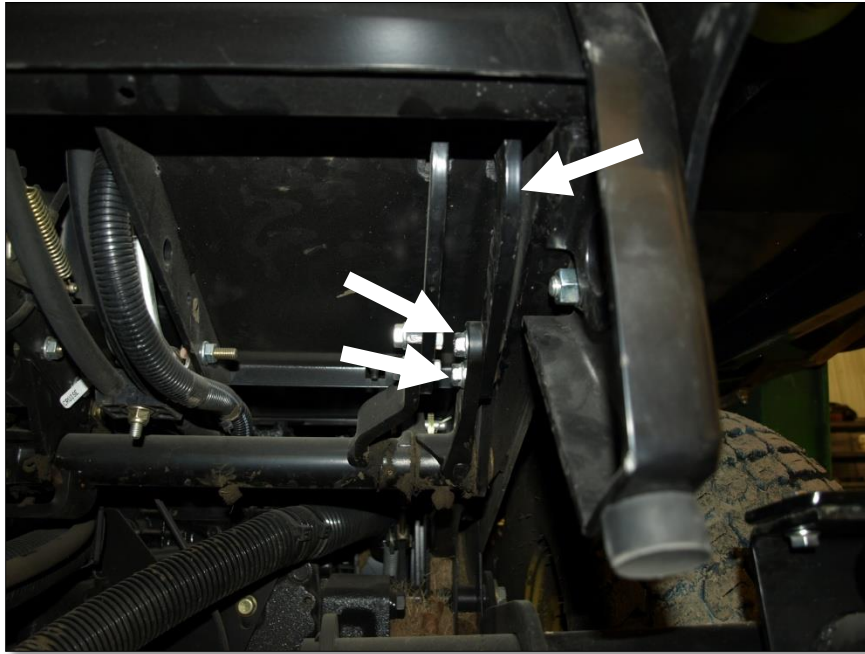

. Un-bolt and remove the outer right reverse traction pedal from the from the mount underneath the operator platform, M8 x 25 fasteners.

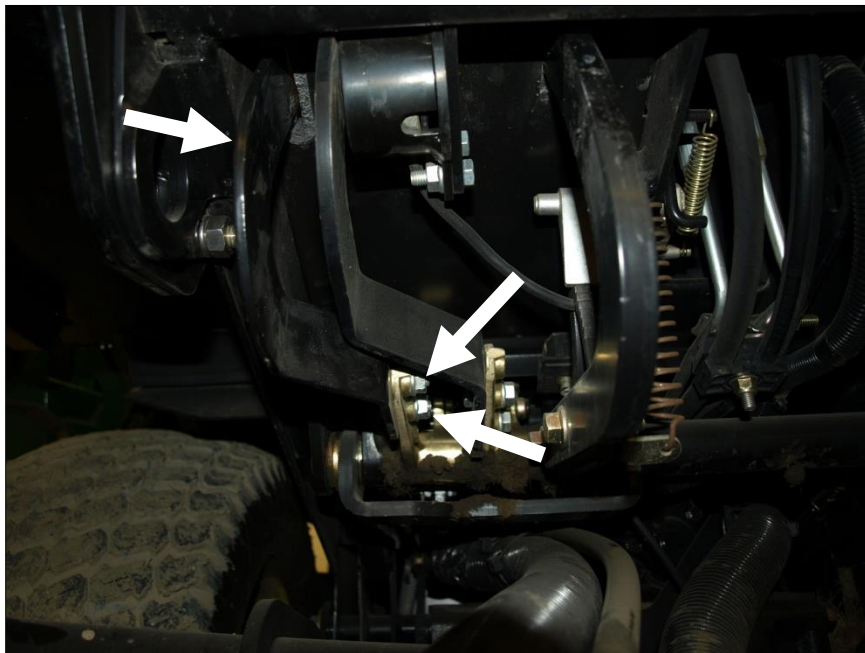

. Open left cab door and un-clip the door gas shock. To remove the gas shock on the left cab door, slide a flat screwdriver underneath the small clip on the end cap that must be pulled UP

order to pop the shock off of the ball stud. **The shock will release very easily when this is accomplished.** Lift the door assembly straight up and off of the cab and put aside for now. Lift shock up off of shock pin, and remove the left door by lifting straight up. Remove the right door using the same procedure.

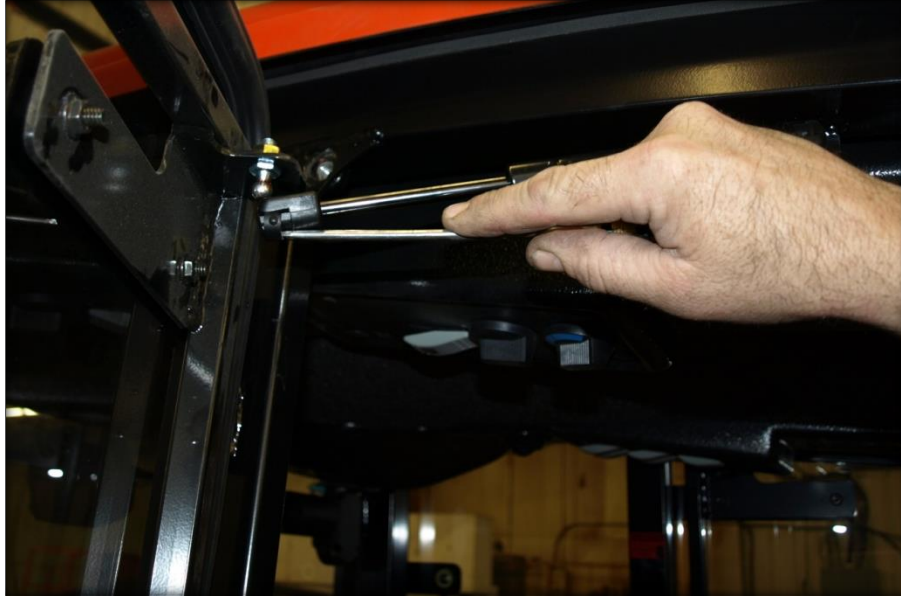

- . Un-bolt and remove the rear removable cab shield.
- . Take one of the cab lift brackets along with a  $\frac{1}{2}$ " x  $4 \frac{1}{2}$ " hex bolt and bolt the lift bracket to the weld nut located behind the tab at the top rear corner of the door opening on the left side. Repeat for the right side.
- . Attach a lift strap or chain to both lifting brackets over top of the roof of the cab and connect to an over-head hoist or forklift.
- . Un-bolt the shipping pallet from the cab and lift up off of the shipping pallet.
- . Position the cab directly over the machine above the operator platform and slowly lower the cab down onto the front and rear mounting brackets.
- . For the rear mounts, use the provided  $\frac{5}{8}$ " x 3" hex bolt, heavy flat washer through the top of the cab mount, and then the  $\frac{5}{8}$ " flange nut underneath the mounting bracket plate. For the front mounts, use the  $\frac{5}{8}$ " x 3" hex bolt through the cab mount and isolator, then the heavy flat washer and flange nut from underneath the bracket.
- . As soon as all mounting bolts are started, you can apply final mount torque. For the  $\frac{5}{8}$ " ROPS fasteners, use 205 ft-lbs, for the M12 bolts use 98 ft-lbs.

- . Remove lift strap/chain from over-head hoist/forklift. Un-bolt and remove the left and right cab lift brackets and bolts. Store for future use if you intend to remove the cab in the future.
- . Re-install the outer reverse traction pedal and the outer brake pedal.
- . Locate the wire harness at the rear corner of the cab and route the harness into the hood area around the lift arm and up and underneath the hood opening gap on the side. Use the provided zip ties to anchor the harness and prevent it from interfering with moving parts on the mower.
- . Connect the heavy red wire to constant 12v power (battery positive) with provided ¼" loop connector. Solder connector to wire. Connect the heavy black wire to ground (battery ground) with provided ¼" loop connector. Solder connector to wire.
- . Remove the right-side panel of the tractor.



- . Connect the orange wire to a key switch activated source on the mower. Use a test light to verify that the wire is key switch activated. Solder the wire directly to the wire on the control box below, use provided shrink wrap on wire after solder.



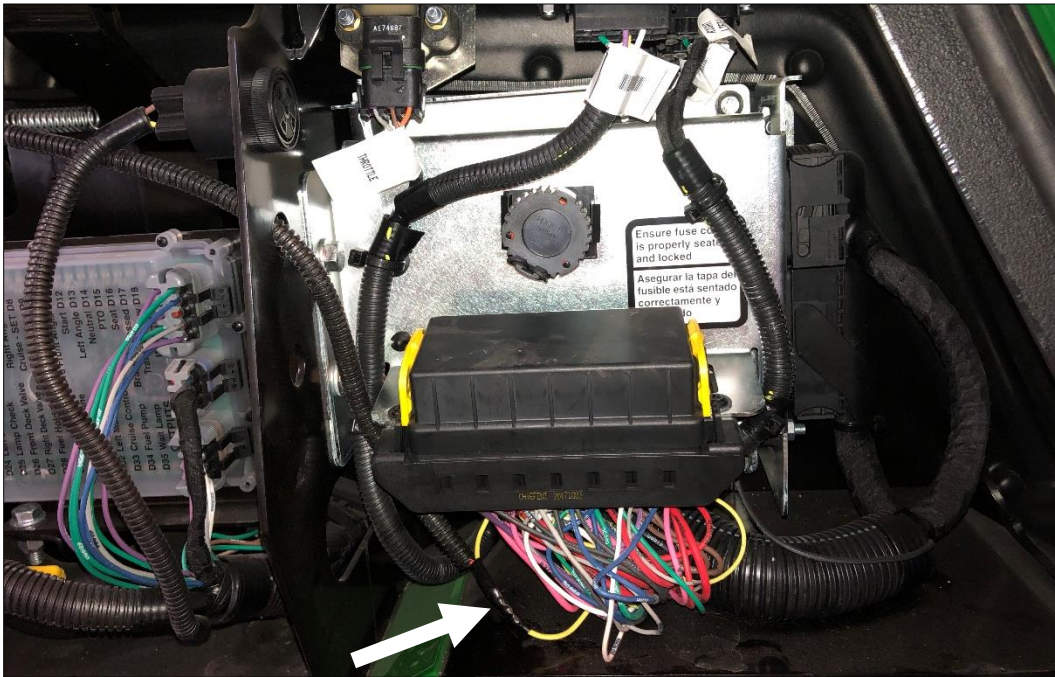

*If cab is equipped with heater option, please proceed with the following steps.*

. Locate the hoses on the left rear corner of the cab. The hose BESIDE the rear window is the PRESSURE hose. PLEASE NOTE that correct connection of the hoses to the proper fitting IS extremely important to prevent the water valve from leaking in the cab. The flow MUST be in the correct direction!

. Route the hoses around the wing deck pocket and through the opening space between the side of the hood and chassis. Use the provided zip ties to secure the hoses into place and prevent them interfering with moving components on the machine.

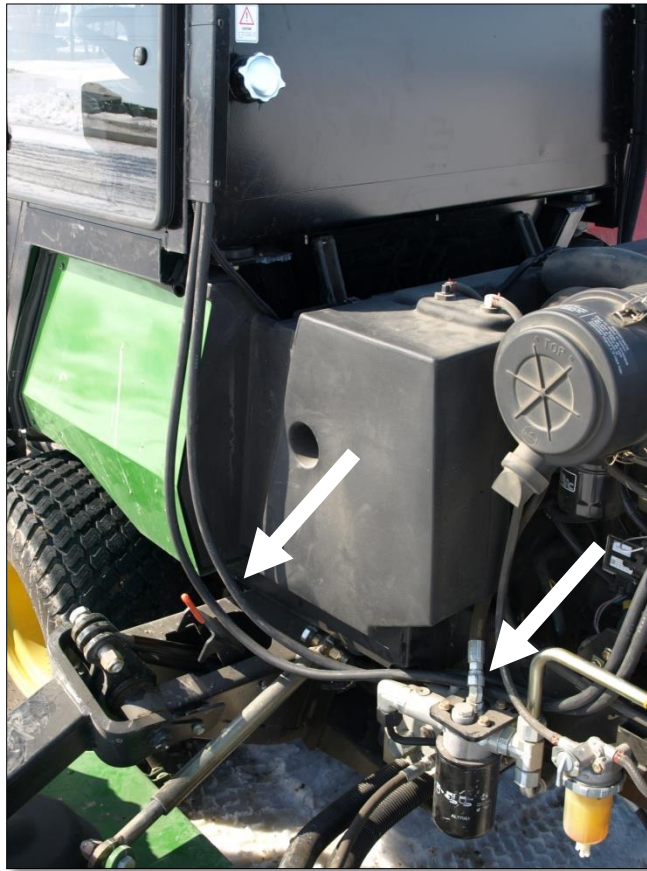

- . Route the PRESSURE hose side to the pressure fitting installed earlier and cut the hose and install onto the fitting. Use the provided HS-6 hose clamp to securely fasten onto engine.
- . Route the other end of the hose to the suction fitting, shortening hose if necessary and connect to fitting, using the provided HS-6 hose clamp.
- . Once all fittings are tightened, engine coolant can be re-filled.
- . Turn the fan to the high position, open water valve control in cab fully and start engine.
- . Run engine at high speed to increase the coolant temperature and force thermostat to open and start to remove airlocks that are in the coolant lines. This may take a few minutes, air coming out of vents in the cab should be very hot. To ensure heater is bleeding out air as fast as possible, consider putting a funnel into radiator cap area and fill funnel with coolant. When the thermostat opens, it will suck the coolant into the system.

*Heater installation is now complete!*

- . Remove the diesel fuel cap. Take some Teflon tape and wrap around the threads of the fuel tank fill port. Keep wrapping around until the large bumps of the thread are smoothed out, this will the fuel hose to fit nice and tight. Take the fuel hose elbow and push down over the fuel

tank threads. It will be necessary to cut one end of the hose to fit precisely. Use the provided HS-36 hose clamp to securely fasten the elbow to the tank. Connect the opposite end to the cab and use HS-36 hose clamp to tighten onto cab.



. Take the main cab floormat and position onto the operator foot platform around the centre console and pedals. Ensure that all pedals have full travel clearance, notching floormat if necessary. Use aerosol spray glue, 3M High Strength 90 recommended, to glue floormat into place.



- . Take the rear shield removed earlier and re-install onto cab.
- . Take ensure a better seal of all weather stripping and floor mat pieces, it is recommended that you use a black silicone seal to seal the cab parts to the tractor.

*Air conditioner installation can now be completed*

- . Route the air conditioner hoses located at the right rear corner of the cab around to the engine bay. The hoses will slide by the pocket on the side of the machine and then under the opening between the hood and the chassis. Use the provided zip ties to secure hoses and prevent them from interfering with machine components.



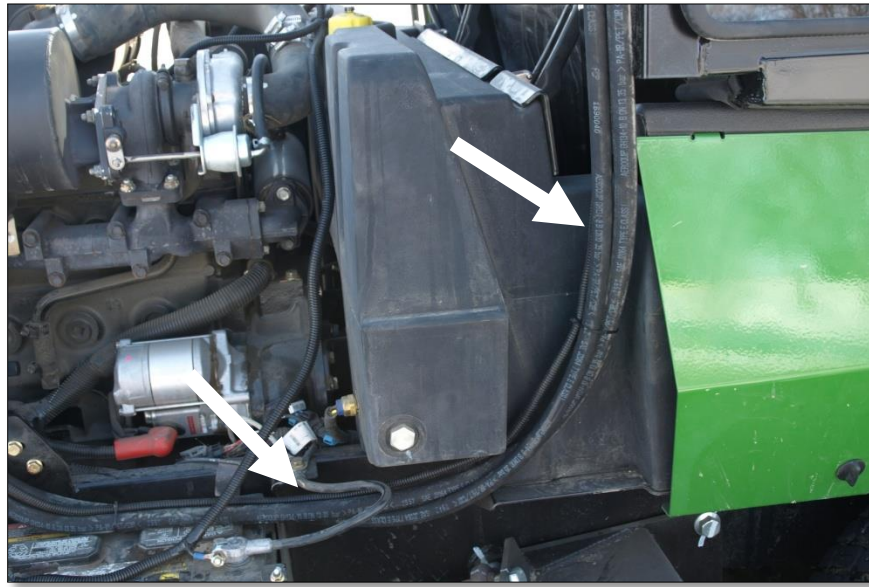

. Route hoses towards compressor, ensure O-ring is seated in # 10 fitting, and install # 10 hose onto # 10 fitting on the compressor.

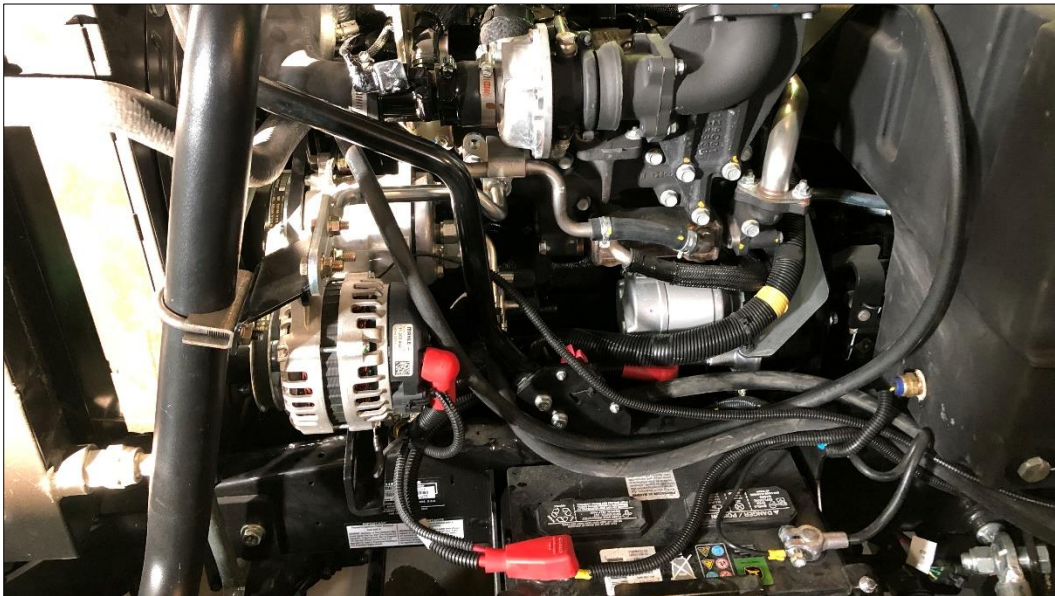

. Ensure the O-ring is seated in # 8 fitting and install remaining hose onto compressor.

. Take the cab compressor clutch wire that is with the hoses and install onto the bullet on the compressor.

**The air conditioning system is now ready for evacuation and pressurization. A licensed air conditioner installer must perform the install. The air conditioning system is designed to use 2 lbs of R134a coolant. The compressor is pre-filled with 3.5 fluid oz of SP15 oil.**

## John Deere 1600 Turbo WAM Series 3 ROPS Cab



\*\*Shown with optional equipment

### John Deere JD1600S3-001 1600T WAM Series 3 ROPS Cab

This ROPS cab is designed and built to fit:  
John Deere 1600 Turbo WAM Series 3.

Designed and built by:

**Tektite Manufacturing Inc:**  
P.O. Box 639, 427 Buffalo Street  
Winkler, MB, Canada  
R6W 4A8  
PH: 204-331-3463  
[parts@tektite.ca](mailto:parts@tektite.ca)

One-year standard product warranty provided by Tektite Manufacturing Inc.  
[www.tektite.ca](http://www.tektite.ca) / [www.tektitecabs.com](http://www.tektitecabs.com)





**DO NOT PROCEED FURTHER UNTIL YOU HAVE READ THE INFORMATION BELOW.**

- 1) Always wear personal protective equipment.
- 2) A minimum of two people is necessary to safely install the cab.
- 3) This ROPS cab is heavy. A lift assist device such as an overhead hoist or high lift forklift is required.
- 4) Ensure your work area is well ventilated. The installation requires the starting of the tractor which will produce dangerous carbon monoxide fumes.
- 5) Read through the entire installation manual first.
- 6) Follow the installation instructions in order.
- 7) Reading the operators manual prior to using the ROPS cab.

## Tektite Limited Warranty

Tektite Manufacturing Inc. (“Tektite”) warrants to the original purchaser (the “Claimant”), that Tektite products will be free from defective materials or workmanship, under normal use and service, for a period of (1) full year from the original invoice date. Tektite’s liability under this Limited Warranty is limited to the repair or (at the discretion of Tektite) the replacement of those components of its products, which were manufactured by Tektite that are defective in materials or workmanship. Tektite shall have no liability under this Limited Warranty unless Tektite is notified of the defect during the stated Warranty Period.

Limitations and Exclusions: Tektite has no responsibility to a Claimant under this Limited Warranty or on any other basis for any of the following:

- a) defects caused, in whole or in part, by accident or misuse, negligence or failure to maintain the product or component;
- b) products or components sold to a customer on an “as is” basis;
- c) wiper blades, light bulbs, fuses, clear vinyl or other consumables;
- d) glass where the point of failure has not been preserved intact and delivered to Tektite for analysis of the cause of the failure;
- e) products or components which have been modified after shipping from Tektite to its customer;
- f) transportation charges for returned, repaired or replacement items;
- g) defects that are subject of a Tektite initiated recall where the Claimant fails to comply with the terms of the recall notice that comes to the attention of the Claimant;
- h) components of Tektite products that are manufactured by third parties (Tektite’s only obligation in relation to such components shall be to accord to the Claimant the benefit of any transferable warranty accorded to Tektite by third party manufacturer);
- i) defects in workmanship or materials in products or components that are repaired or replaced by Tektite unless Tektite is notified of the new defect within the Warranty Period that applied to the original product or component that has been repaired or replaced;
- j) defects that result, in whole or in part, from inadequate engineering or specifications provided to Tektite by its customer;
- k) any actual or alleged deficiency in technical or engineering services or advice provided by Tektite to its customer whether provided for valuable consideration or otherwise;
- l) consequential damages, or any other damages whether foreseeable or not, resulting from the defect or any delay in remedying the defect;
- m) any breach or alleged breach of any implied warranty of merchantability or fitness for particular purpose of use;
- n) defects or part failure due to misuse or failure to follow recommended cab installation procedures; and
- o) travel expenses, including mileage.

This Limited Warranty expresses the entire obligation of Tektite, its officers, directors, agents and employees, to its customer or any Claimant in respect of any defect in workmanship, or materials of any product or component sold or manufactured by Tektite whether on grounds of breach of contract, negligence or other tortious liability, breach of express or implied warranty or other basis in law of any jurisdiction.

Acceptance by a customer of delivery of products of Tektite constitutes acceptance of this Limited Warranty in lieu of all other warranties express or implied including without limitation all implied warranties of merchantability or fitness for particular purpose or use and constitutes acceptance by customer of the exclusions and limitations of the liability of Tektite set out above. Once received, the cab should have ALL exterior cardboard, Styrofoam wrapping removed for immediate inspection of product to ensure that no damages have occurred during transportation. Outer coverings should stay off the cab and the cab be stored indoors in a controlled environment. The warranty card must be completed and returned to Tektite.

Warranty claims should be reported to [parts@tektite.ca](mailto:parts@tektite.ca). A warranty claim form and instructions will be provided at this time. Warranty work not pre-authorized by Tektite may not be covered by this warranty agreement. Labor rate and time allowances are fixed by Tektite. Approved warranty claims will be issued in the form of credits applied to customer account.

## Safety Precautions

### *Safety First*

Read these instructions carefully. It is essential that you read the instructions and safety regulations before you attempt to assemble or use the features that are on this cab/ROPS.

**Danger:** Indicates an immediate hazardous situation which, if not avoided, will result in death or serious injury.

**Warning:** Indicates a potentially hazardous situation which, if not avoided, may result in death or serious injury.

**Caution:** Indicates a potentially hazardous situation which, if not avoided, may result in minor or moderate injury.

**Important:** Indicates that cab or property damage may result if instructions are not carefully followed.

**NOTE:** All products are designed to give safe, dependable service if they are operated and maintained according to instructions. It is the owner's responsibility to be certain anyone operating this product reads this manual, and all other applicable manuals, to become familiar with this cab and all safety precautions. Failure to do so could result in serious personal injury or cab damage. If you have any questions, consult your dealer. Read and understand this manual before operation.

**NOTE:** A safe operator is the best assurance against accidents. All operators, no matter how experienced they may be, should read this operator manual and all other related manuals before attempting to operate features in this cab/ROPS and operate the base tractor. Please read the following section and pay particular attention to all safety recommendations contained in this manual and those labelled on the cab and on the tractor.



## General Safety

1. Never let an unqualified or untrained driver operate the tractor.
2. Keep a fire extinguisher, with ABC rating securely fastened in the ROPS. Maintain it and be familiar with its use.
3. Do not carry passengers.
4. Never operate the tractor in a closed building for a prolonged period. Ensure adequate ventilation is present, as engine exhaust fumes are poisonous and can kill.
5. Always keep sleeves, jackets or other loose clothing relatively tight and belted. Loose clothing may catch on moving parts and result in severe personal injury or death.
6. Provide a first-aid kit, securely attached inside of the ROPS for use in case of accident.
7. Never jump from the tractor. There is a danger of tripping or falling on protruding parts.
8. Use steps and hand holds when mounting and dismounting the tractor, or for servicing components too high to reach from the ground.
9. When seated in the ROPS, fasten seat belt before starting the engine. A proper seat belt must be worn at all times when using a ROPS.
10. Safety devices and shields are intended to protect operators from injury or death. Under no circumstances should they be modified, disabled or removed.

## Operating Safety

1. Always operate the tractor controls while sitting in the operator's seat.
2. Lock seat in position and buckle seat belt before operating the tractor.
3. Avoid abrupt sharp turns at high speeds.
4. On sloped terrain, do not make sharp turns as machine stability could be compromised.
5. Operate the tractor smoothly, avoid abrupt starts and stops.
6. Keep all shields in place when operating the tractor.
7. Do not operate the tractor when you are tired, sick, or impaired.
8. Never operate the tractor in confined areas; visibility next to the tractor is reduced. Injury to bystanders or damage to the ROPS or equipment may result.

## Safety

Carefully review the procedures given in this manual and the tractor operator's manual with all operators annually. It is important that all operators become familiar with, and follow safety precautions. Operating instructions must be given to everyone using the tractor before operation and at least once yearly thereafter in compliance with OSHA Regulations 1928.57 (United States).

### **Safe Operation on Rough Terrain**

1. Drive the tractor slowly on hillsides and curves to eliminate the danger of tipping. Avoid slopes which are too steep for safe operation. Avoid sharp uphill turns.
2. Always drive slowly enough over rough ground or obstructions. Drive at speeds slow enough to ensure your safety.
3. When driving out of a ditch, gully, or up a steep hillside, engage the clutch slowly. Avoid sharp uphill turns.
4. When descending steep grades, select a sufficiently low gear to maintain control with minimum use of braking.
5. Use caution when driving near the edge of a ditch or gully. It may cave in, causing the tractor to roll over.
6. Be alert when operating near trees, slopes and around obstructions. Tree branches can cause damage to ROPS components.

### **Maintenance Safety**

1. Remove mud, crop residue, chains, and tools from steps and operator's platform. They may interfere with pedal operation or entry/exit from tractor.
2. When servicing components are too high to reach from the ground use steps and handholds. Do not use fenders or shields that are not designed as steps.

### **Safe Highway Operation**

1. Before operating the tractor on, or near, public roadways check with your local authorities for any local regulations that will affect you.
2. Equip towed implements with slow moving vehicle (SMV) signs when traveling on public roads.
3. Install additional lights on implement rear to safeguard against rear end collisions.
4. Use hazard warning flashers as required by law when transporting or driving on public roads. If the tractor had warning flashers removed when mounting the ROPS, they must be replaced prior to operation on public roads.
5. Keep to the right, yielding right-of-way traffic, especially if pulling implements. Pull off the road and stop to allow motorists to pass. Drive on the road shoulder, if permitted by law.
6. Use extreme caution when pulling heavy loads at road speeds. Avoid hard application of the tractor brakes at high speed.
7. Always drive slowly near curbs, approaches or ditches.
8. If equipped, ensure headlights are aligned so they will not blind the operators of oncoming vehicles. If the tractor is not equipped with turn signals and law requires them, install them prior to operating on or near public roads.
9. Use your turn signals, checking for traffic well in advance of turning. If the tractor is not equipped with turn signals and law requires them, install them prior to operating on or near public roads.



## Safety Decals

1. Keep decals clean. Remove dirt with a wet clean cloth when necessary.
2. Replace safety decals if destroyed, missing, painted over or unreadable. If any safety decals are covered or obscured when the ROPS is mounted, it is recommended that you purchase replacement decals from the tractor manufacturer. Mount them in a readable location at, or near, their original location before operating the tractor.
3. New ROPS decals and tractor decals are available from your tractor dealer.

## ROPS Safety

1. Install the ROPS in accordance with Tektite mounting instructions. Failure to do so may affect the ROPS ability to withstand a roll over.
2. If the ROPS is subjected to alteration, structural damage or involved in an over turn accident, the entire structure must be replaced. Failure to do so may result in injury or death in the event of a roll over.
3. If the tractor is not equipped with seat belts, purchase approved seat belts from the tractor manufacturer or Tektite prior to operating the tractor.
4. Always fasten seat belts prior to operating the tractor.
5. Always operate the tractor from the operator's seat.
6. Remove mud, crop residue, chains and tools from steps and operator's platform. They may interfere with pedal operation or entry/exit from the tractor.
7. Remove all loose chains, tools, and equipment from the operator's platform. Failure to do so may cause injury or death in the event of a roll over.
8. Do not install the ROPS on a tractor model that the ROPS is not designated for (compatible tractor designations are printed on the ROPS serial number plate). The ROPS is designed specifically for individual models to ensure ROPS requirements will be met. Installing the ROPS on a non designated tractor may result in injury or death.

## Emergency Exits

The ROPS cab has two doors. Either one can be used during an emergency.

## Operating Instructions

### Important

The following section locates, identifies and briefly describes the functions of all cab controls. All operators should familiarize themselves with control location and function prior to operating the mower. Failure to do so may result in unsafe operation of the mower and possible injury or death to operators and bystanders.

There are two switch plates located in the headliner. The following switches are available, and their functionality is described.

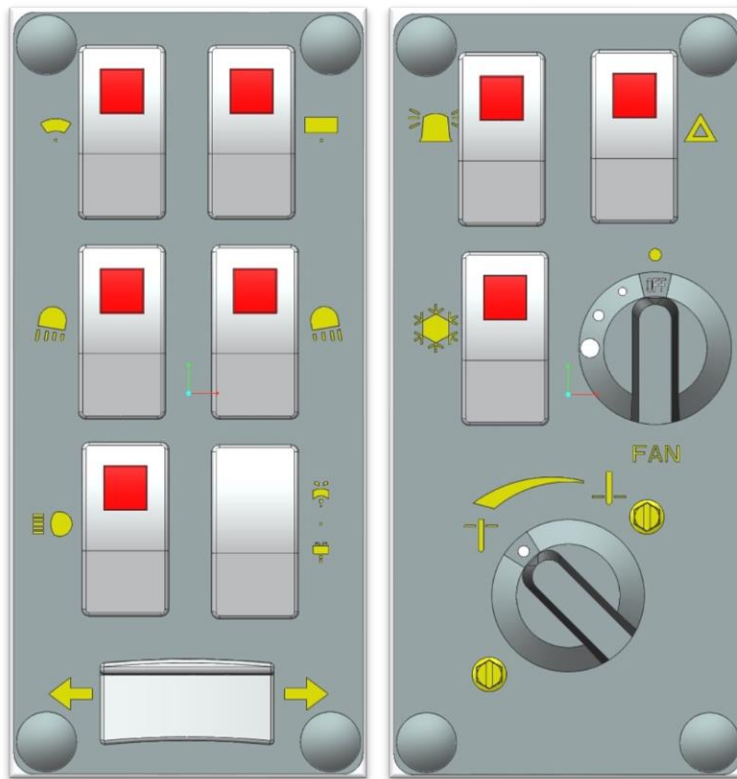

### Left Switch Plate

#### 1. Front Wiper Rocker Switch (standard)

Low position: Off

High position: On

Note: indicator light activates when wiper is on.

#### 2. Rear Wiper Rocker Switch (optional)

Low position: Off

High position: On

Note: indicator light activates when wiper is on.

**3. Front Work Light Rocker Switch (optional)**

Low position: Off

High position: On

Note: indicator light activates when work lights are on.

**4. Rear Work Light Rocker Switch (optional)**

Low position: Off

High position: On

Note: indicator light activates when work light is on.

**5. Head Lights Rocker Switch (optional)**

Low position: Off

High position: On

Note: indicator light activates when head lights are on.

**6. Front and Rear Washer Rocker Switch (optional)**

Low position: Momentary – On Rear Washer

Middle position: Off

High position: Momentary – On Front Washer

**7. Turn Signal Rocker Switch (optional)**

Left position: On

Middle position: Off

Right position: On

**Right Switch Plate****1. Beacon Rocker Switch (optional)**

Low position: Off

High position: On

Note: indicator light activates when beacon is on.

**2. Hazard Rocker Switch (optional)**

Low position: Off

High position: On

Note: indicator light activates when 4-way flashers are on.

**3. Air Conditioner Rocker Switch (optional)**

Low position: Off

High position: On

Note: indicator light activates when air conditioner is on.

**4. Fan Rotary Switch (optional)**

Indicator mark above switch indicates whether fan is operational or not.

### 5. Temperature Control Rotary Switch (optional)

Indicator mark at lower left corner indicates current temperature setting. Rotate to increase heat output or to decrease heat output of heating system. When air conditioner is being used, it is recommended that the switch be at maximum cooling position.

### Cab Circuit Protection

The Tektite ROPS cab is wired to provide maximum protection against accidental battery rundown and circuit overload. A relay in the cab is ignition activated and prevents the operator from accidentally leaving fan motors, lights on after turning the tractor off and leaving for the day. A circuit breaker is provided to prevent the cab electrical components from drawing more power than they should be able to from a dead short. The cab electrical components are also fused individually, and the fuse block is in the headliner, directly above the door opening on the left side. Locate the 3" snap cap, and with a small flat screw driver you can remove the cap to examine the fuses provided. A decal on the fuse block indicates which fuse is for which electrical option.

### After your ROPS Cab has been installed:

Before starting a mower equipped with a Tektite ROPS cab:

1. Clear the operator platform of all tools. Tools left in or around the ROPS and mower can cause operator interference which could lead to bodily injury and/or damage the machine.
2. Inspect the ROPS and mower to ensure all bolts are tight and re-tighten if required.
3. Ensure that all pedals, levers, and controls have adequate clearance for normal operation.
4. Ensure that all electrical components of both the ROPS and mower operate normally.
5. Ensure your door latches properly onto the striker pin. Immediately after installation, the ROPS frame may flex slightly from installation, and the door latch will need to be re-aligned for proper operation. Loosen the striker pin, striker mounting plate and door latch as necessary to get a proper alignment of the door striker.

### Service Parts Breakdowns:

Following are parts breakdowns for components that may require service parts replacement during the life of the ROPS. If you require replacement parts, please contact the dealer that you purchased the ROPS from and indicate which parts you require.



Index	Service Part #	File Name	Description	Qty
1	A00-0013	TEKT-0009	5MM Bushing	8
2	A00-0019	STEP-BOLT1-4X1	Step Bolt, 1/4" x 1", MB	4
3	A00-0021	FLANGE-NUT-1-4	Flange Nut, 1/4", YD	4
4	A00-0044	TEKT-ASM-002	Side Window Hinge Weldment	2
5	A00-0057	TEKT-0020MIR	Side Window Latch, L60776	1
6	A00-0058	CARRIAGE_BOLT-5-16X1	Bolt, Carriage, 5/16"x 1", YD	1
7	A00-0059	HEX-NUT-5-16	Hex, Nylon Locking Nut, 5/16", YD	1
8	A00-0087	TEKT-0028	Side Window Slider Bracket 2" tube	1
9	A00-0119	WASHER_1-4	Washer, Flat, 1/4"	2
10	J03-0006	JDWAM-042	Right Side Window	1
11	J03-0014	JDWAM-088	Right Side Window Seal	1

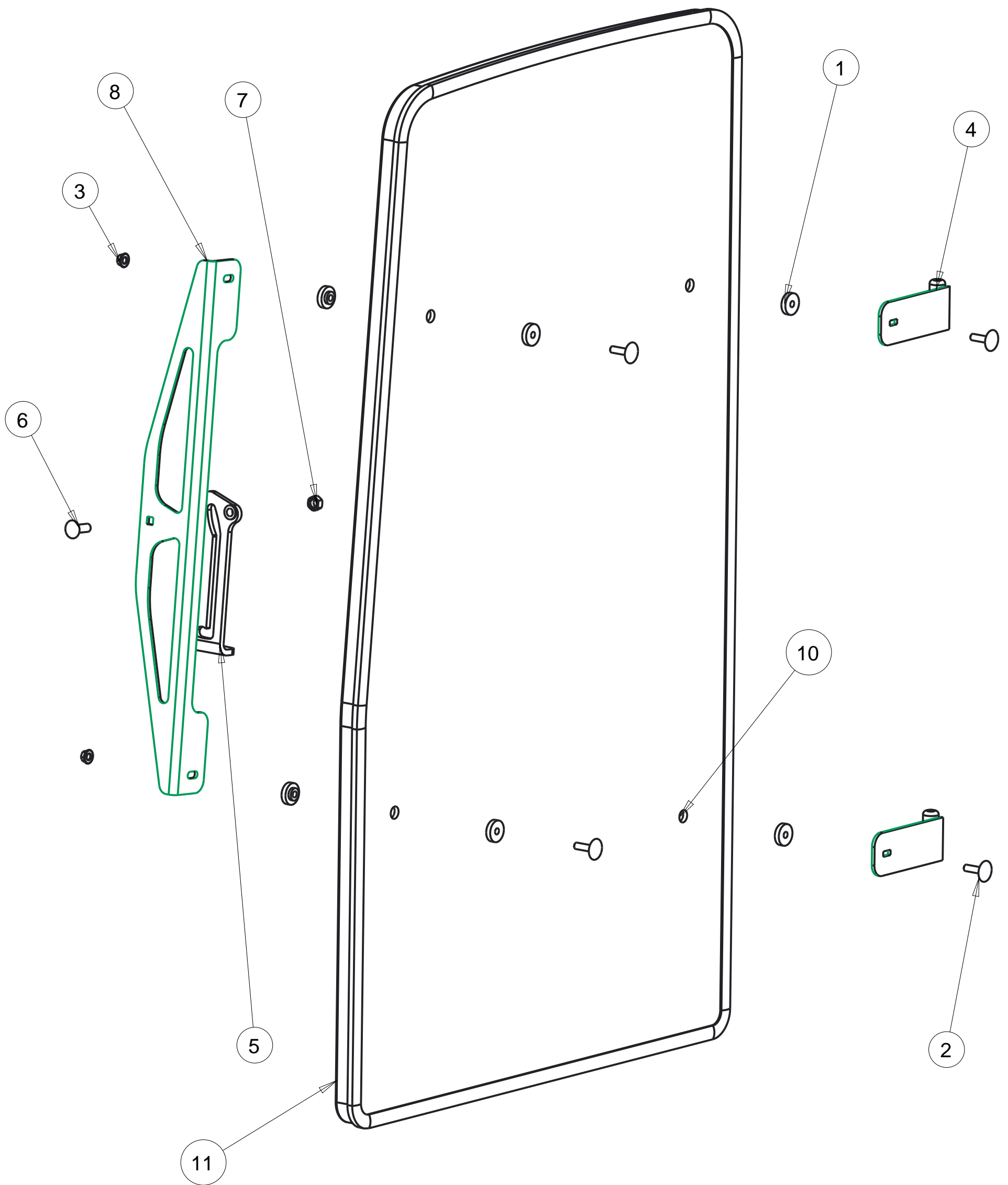

**Tektite Manufacturing Inc.**  
24157 Hwy 3, Box 639, Winkler MB, R6W 4A8, Canada

**Notice of Confidentiality**

This material is property of Tektite Manufacturing Inc and is not to be used by the recipient for any purpose other than the purpose for which it was transmitted. The material remains the property of Tektite and shall be returned upon request. The material may not be reproduced or disclosed to third parties without the written consent of Tektite.

**Tolerances:**

Unless otherwise specified

X.X =  $\pm 1/16"$   
Angular =  $\pm 1.0^\circ$

Req'd: <b>1 req</b>	CNC:	Description: <b>Right Side Window Assembly</b>	
Drawn By: <i>Daryl Furkalo</i>	Date: 2013-03-25	Units: <b>Imp.</b>	File Name: JDWAM-ASM-015_OP
Checked By:	Date:	Size: <b>B</b>	

Index	Service Part #	File Name	Description	Qty
1	A00-0013	TEKT-0009	5MM Bushing	8
2	A00-0019	STEP-BOLT1-4X1	Step Bolt, 1/4" x 1", MB	4
3	A00-0021	FLANGE-NUT-1-4	Flange Nut, 1/4", YD	4
4	A00-0046	TEKT-ASM-002R	Side Window Hinge Right	2
5	A00-0056	TEKT-0020	Side Window Latch, L60775	1
6	A00-0058	CARRIAGE_BOLT-5-16X1	Bolt, Carriage, 5/16"x 1", YD	1
7	A00-0059	HEX-NUT-5-16	Hex, Nylon Locking Nut, 5/16", YD	1
8	A00-0087	TEKT-0028	Side Window Slider Bracket 2" tube	1
9	A00-0119	WASHER_1-4	Washer, Flat, 1/4"	2
10	J03-0004	JDWAM-040	Left Side Window	1
11	J03-0013	JDWAM-087L	Left Side Window Seal	1

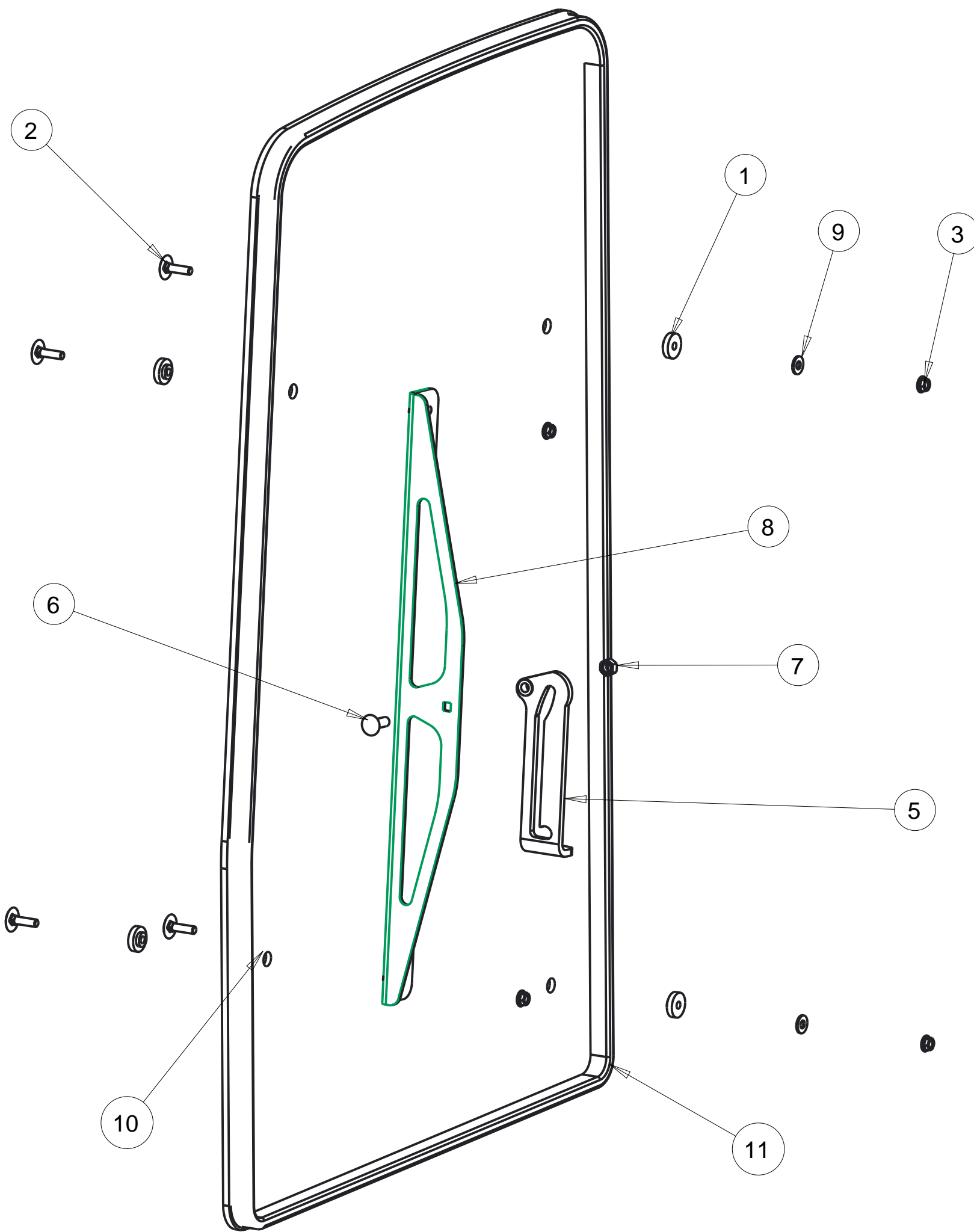

**Tektite Manufacturing Inc.**  
24157 Hwy 3, Box 639, Winkler MB, R6W 4A8, Canada

**Notice of Confidentiality**

This material is property of Tektite Manufacturing Inc and is not to be used by the recipient for any purpose other than the purpose for which it was transmitted. The material remains the property of Tektite and shall be returned upon request. The material may not be reproduced or disclosed to third parties without the written consent of Tektite.

**Tolerances:**  
Unless otherwise specified

X.X =  $\pm 1/16"$   
Angular =  $\pm 1.0^\circ$

Req'd: <b>1 req</b>	CNC:	Description: <b>Left Side Window Assembly</b>	
Drawn By: <i>Daryl Furkalo</i>	Date: 2013-03-25	Units: <b>Imp.</b>	File Name: <b>JDWAM-ASM-014_OP</b>
Checked By:	Date:	Size: <b>B</b>	

Index	Service Part #	File Name	Description	Qty
1	A00-0001	DLP-HANDLE	Outside Push Button Handle	1
2	A00-0003	RIGHT-LATCH	Suicide Door Right Latch	1
3	A00-0013	TEKT-0009	5MM Bushing	17
4	A00-0018	STEP-BOLT1-4X1-1-2	Step Bolt, 1/4" x 1 1/2", MB	3
5	A00-0019	STEP-BOLT1-4X1	Step Bolt, 1/4" x 1", MB	1
6	A00-0020	STEP-BOLT1-4X1-1-4	Step Bolt, 1/4" x 1 1/4", MB	4
7	A00-0021	FLANGE-NUT-1-4	Flange Nut, 1/4", YD	10
8	A00-0022	FLANGE_BOLT_M6X25	Flange Bolt, M6x25, YD	1
9	A00-0041	TEKTITE-DECAL	Tektite Cab Decal - Solid White	1
10	A00-0042	TEKT-ASM-001R	Right Cab Door Hinge Weldment, Upper	1
11	A00-0059	FLANGE-NUT-5-16	Flange Nut, 5/16", YD	1
12	A00-0084	TEKT-0070	Gas Shock	1
13	A00-0085	TEKT-0069	Gas Shock Stud	1
14	A00-0118	FLANGE_BOLT_1-4X1	Flange Bolt, 1/4" x 1", YD	2
15	A00-0177	TEKT-0068	Handle Washer Spacer	1
16	A00-0229	TEKT-ASM-029R	Right Door Hinge Weldment, Lower	1
17	J03-0007	JDWAM-043	Right Door Glass	1
18	J03-0009	JDWAM-ASM-009	Right Door Frame Weldment	1
19	J03-0011	JDWAM-085R	Right Door Seal	1
20	J03-0018	JDWAM-101	Door Grab Handle, WAM	1

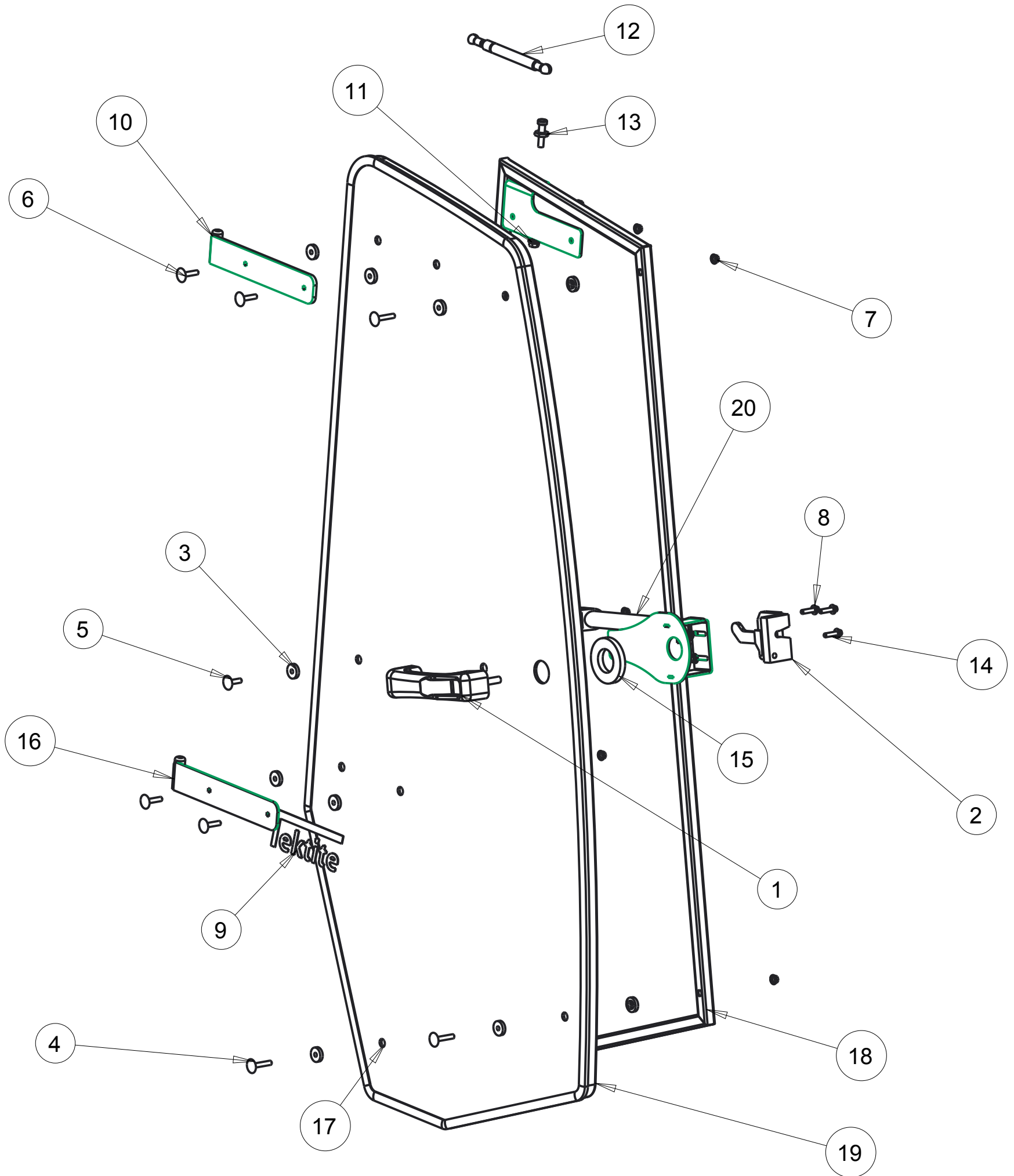

**Tektite Manufacturing Inc.**  
24157 Hwy 3, Box 639, Winkler MB, R6W 4A8, Canada

**Notice of Confidentiality**

This material is property of Tektite Manufacturing Inc and is not to be used by the recipient for any purpose other than the purpose for which it was transmitted. The material remains the property of Tektite and shall be returned upon request. The material may not be reproduced or disclosed to third parties without the written consent of Tektite.

**Tolerances:**  
Unless otherwise specified  
X.X = ± 1/16"  
Angular = ± 1.0°

Req'd:	CNC:	Description: <b>Right Door Assembly</b>	
Drawn By: <i>Daryl Furkalo</i>	Date: 2013-09-23	Units: <b>Imp.</b>	File Name: JDWAM-ASM-008_OP
Checked By:	Date:	Size: <b>B</b>	

Index	Service Part #	File Name	Description	Qty
1	A00-0001	DLP-HANDLE	Outside Push Button Handle	1
2	A00-0002	LEFT-LATCH	Suicide Door Left Latch	1
3	A00-0013	TEKT-0009	5MM Bushing	17
4	A00-0018	STEP-BOLT1-4X1-1-2	Step Bolt, 1/4" x 1 1/2", MB	3
5	A00-0019	STEP-BOLT1-4X1	Step Bolt, 1/4" x 1", MB	1
6	A00-0020	STEP-BOLT1-4X1-1-4	Step Bolt, 1/4" x 1 1/4", MB	4
7	A00-0021	FLANGE-NUT-1-4	Flange Nut, 1/4", YD	10
8	A00-0022	FLANGE_BOLT_M6X25	Flange Bolt, M6x25, YD	1
9	A00-0039	TEKT-ASM-001	Left Door Hinge Weldment, Upper	1
10	A00-0041	TEKTITE-DECAL	Tektite Cab Decal - Solid White	1
11	A00-0059	FLANGE-NUT-5-16	Flange Nut, 5/16", YD	1
12	A00-0084	TEKT-0070	Gas Shock	1
13	A00-0085	TEKT-0069	Gas Shock Stud	1
14	A00-0118	FLANGE_BOLT_1-4X1	Flange Bolt, 1/4" x 1", YD	2
15	A00-0177	TEKT-0068	Handle Washer Spacer	1
16	A00-0228	TEKT-ASM-029	Left Door Hinge Weldment, Lower	1
17	J03-0005	JDWAM-041	Left Door Glass	1
18	J03-0008	JDWAM-ASM-007	Left Door Frame Weldment	1
19	J03-0010	JDWAM-084	Door Seal	1
20	J03-0018	JDWAM-101	Door Grab Handle, WAM	1

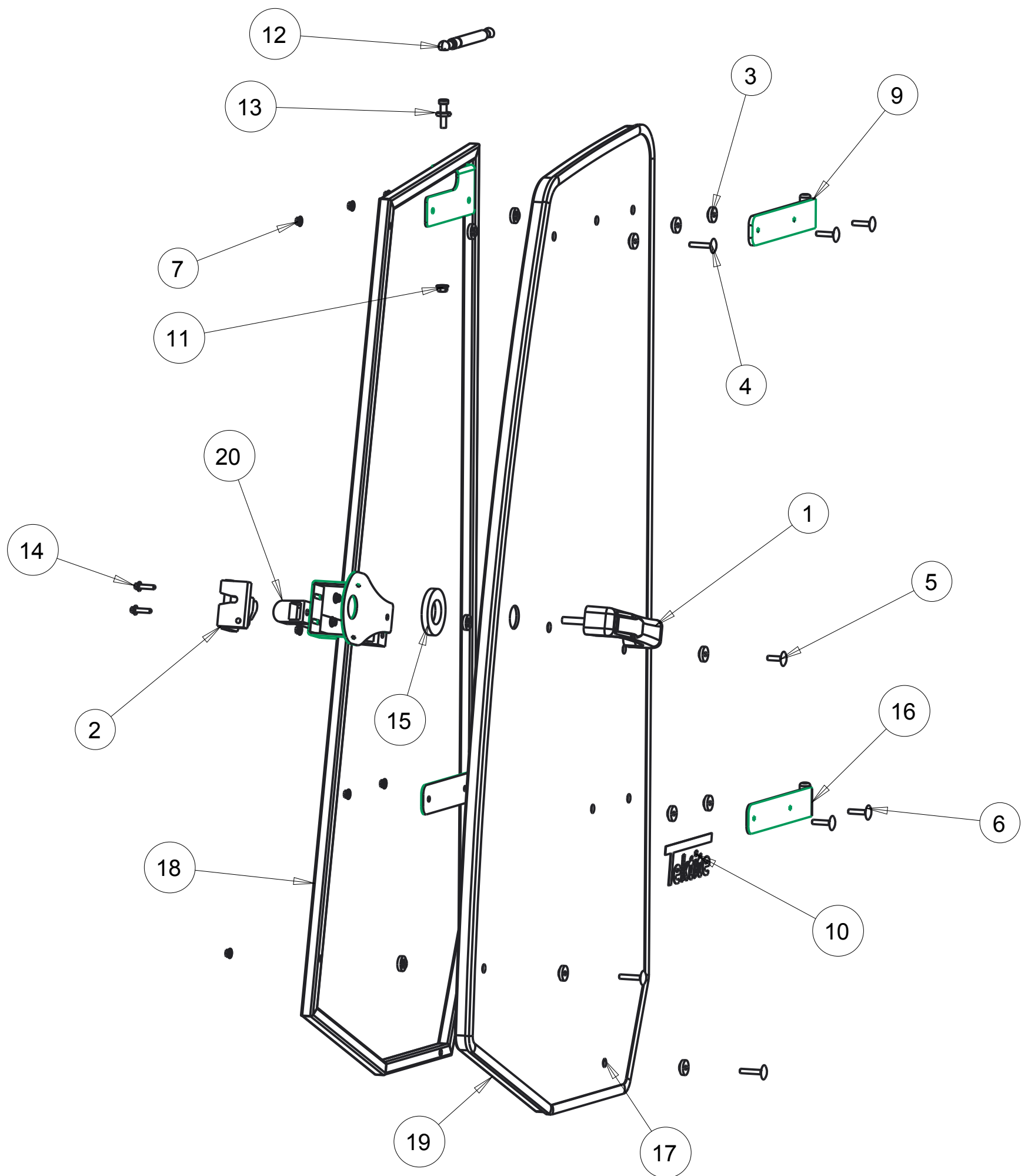

**Tektite Manufacturing Inc.**  
24157 Hwy 3, Box 639, Winkler MB, R6W 4A8, Canada

**Notice of Confidentiality**

This material is property of Tektite Manufacturing Inc and is not to be used by the recipient for any purpose other than the purpose for which it was transmitted. The material remains the property of Tektite and shall be returned upon request. The material may not be reproduced or disclosed to third parties without the written consent of Tektite.

**Tolerances:**  
Unless otherwise specified  
X.X = ± 1/16"  
Angular = ± 1.0°

Req'd:	CNC:	Description: <b>Left Door Assembly</b>	
Drawn By: <i>Daryl Furkalo</i>	Date: 2013-09-23	Units: <b>Imp.</b>	File Name: JDWAM-ASM-006_OP
Checked By:	Date:	Size: <b>B</b>	

Index	Service Part #	File Name	Description	Qty
1	A00-0013	TEKT-0009	5MM Bushing	12
2	A00-0014	TEKT-0092	Thick Bushing	6
3	A00-0020	STEP-BOLT1-4X1-1-4	Step Bolt, 1/4" x 1 1/4", MB	6
4	A00-0021	FLANGE-NUT-1-4	Flange Nut, 1/4", YD	6
5	J03-0003	JDWAM-037	Front Window Glass	1
6	J03-0015	JDWAM-089	Windshield Seal	1

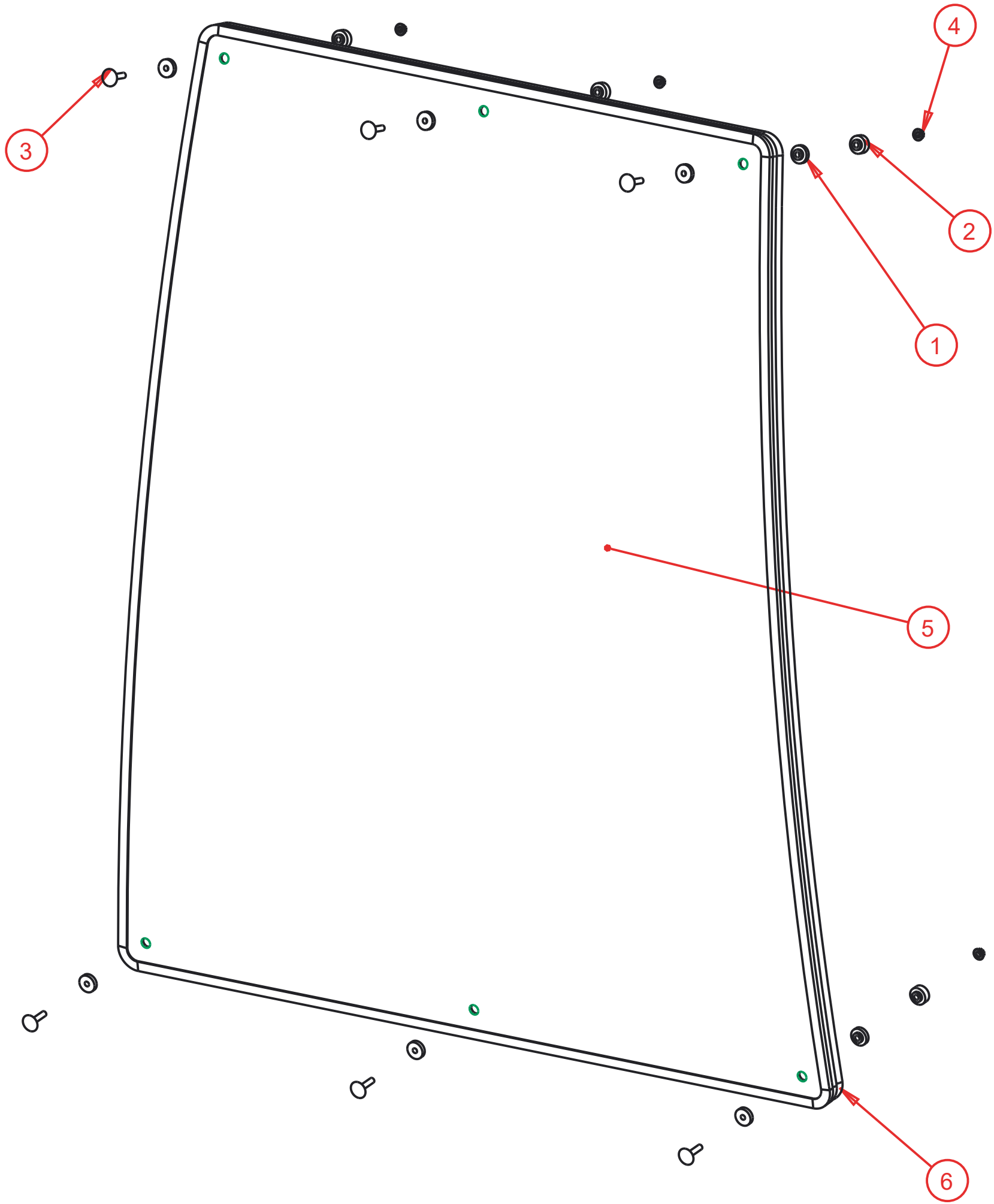

**Tektite Manufacturing Inc.**  
 24157 Hwy 3, Box 639, Winkler MB, R6W 4A8, Canada

**Notice of Confidentiality**

This material is property of Tektite Manufacturing Inc and is not to be used by the recipient for any purpose other than the purpose for which it was transmitted. The material remains the property of Tektite and shall be returned upon request. The material may not be reproduced or disclosed to third parties without the written consent of Tektite.

**Tolerances:**  
 Unless otherwise specified  
 X.X = ± 1/16"  
 Angular = ± 1.0°

Req'd: <b>1 req</b>	CNC:	Description: <b>Windshield Assembly</b>	
Drawn By: <i>Daryl Furkalo</i>	Date: 2017-07-18	Units: <b>Imp.</b>	File Name: <b>JDWAM-ASM-016</b>
Checked By:	Date:	Size: <b>B</b>	



Index	Service Part #	File Name	Description	Qty
1	A00-0013	TEKT-0009	5MM Bushing	14
2	A00-0014	TEKT-0092	Thick Bushing	6
3	A00-0019	STEP-BOLT1-4X1	Step Bolt, 1/4" x 1", MB	1
4	A00-0020	STEP-BOLT1-4X1-1-4	Step Bolt, 1/4" x 1 1/4", MB	6
5	A00-0021	FLANGE-NUT-1-4	Flange Nut, 1/4", YD	7
6	A00-0033	315-080	Rear Wiper Shaft Grommet	1
7	A00-0043	WWF-MOTOR	WWF Wiper Motor, 1" Shaft	1
8	A00-0430	TEKT-ASM-073	Wiper Blade, 16", J-Hook	1
9	A00-0583	TEKT-ASM-100	WWF, Adjustable Radial Arm, J-Hook, Short	1
10	J03-0002	JDWAM-036	Rear Window Glass	1
11	J03-0012	JDWAM-086	Rear Window Seal	1

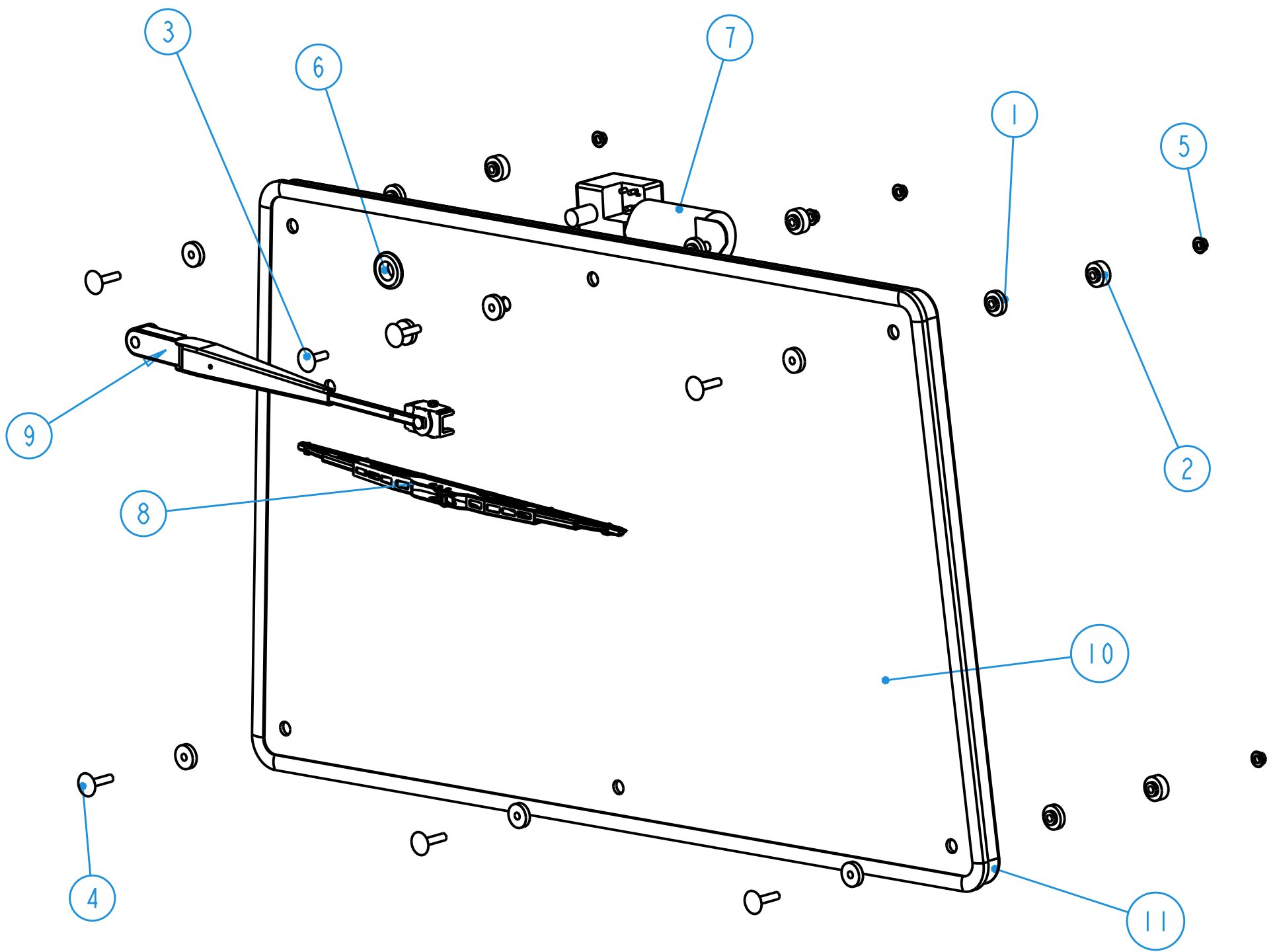

**Notice of Confidentiality**

This material is property of Tektite Manufacturing Inc and is not to be used by the recipient for any purpose other than the purpose for which it was transmitted. The material remains the property of Tektite and shall be returned upon request. The material may not be reproduced or disclosed to third parties without the written consent of Tektite.

**Tolerances:**  
 Unless otherwise specified  
 X.X = ±1/16"  
 Angular = ± 1.0°

<b>Tektite Manufacturing Inc.</b> 427 Buffalo Str, Box 639, Winkler MB, R6W 4A8, Canada			
Req'd: <b>1 req</b>	CNC:	Description: <b>Rear Window Assembly</b>	
Drawn By: <i>Daryl Furkalo</i>	Date: <b>2025-03-20</b>	Units: <b>Imp.</b>	File Name: <b>JDWAM-ASM-010_OP</b>
Checked By:	Date:	Size: <b>B</b>	

Index	Service Part #	File Name	Description	Qty
1	A00-0007	FAN-SWITCH	4-Position Fan Switch	1
2	A00-0054	TEKT-0018	Fan Speed Control Knob	2
3	A00-0055	TEKT-0019	Fir Tree Fastener	4
4	A00-0065	TEKT-ASM-005	On-Off Switch w/Lens	3
5	A00-0252	TEKT-0117	Water Valve Directly on Switch	1
6	A00-0253	TEKT-0119	Right Switchplate Decal, 2014 Update	1
7	A00-0282	SCREW-3-16X3-4	Screw, Self-Tap, 3/16" x 3/4"	2
8	A00-0283	TEKT-0118	Right Switchplate, 2014 Redesign	1

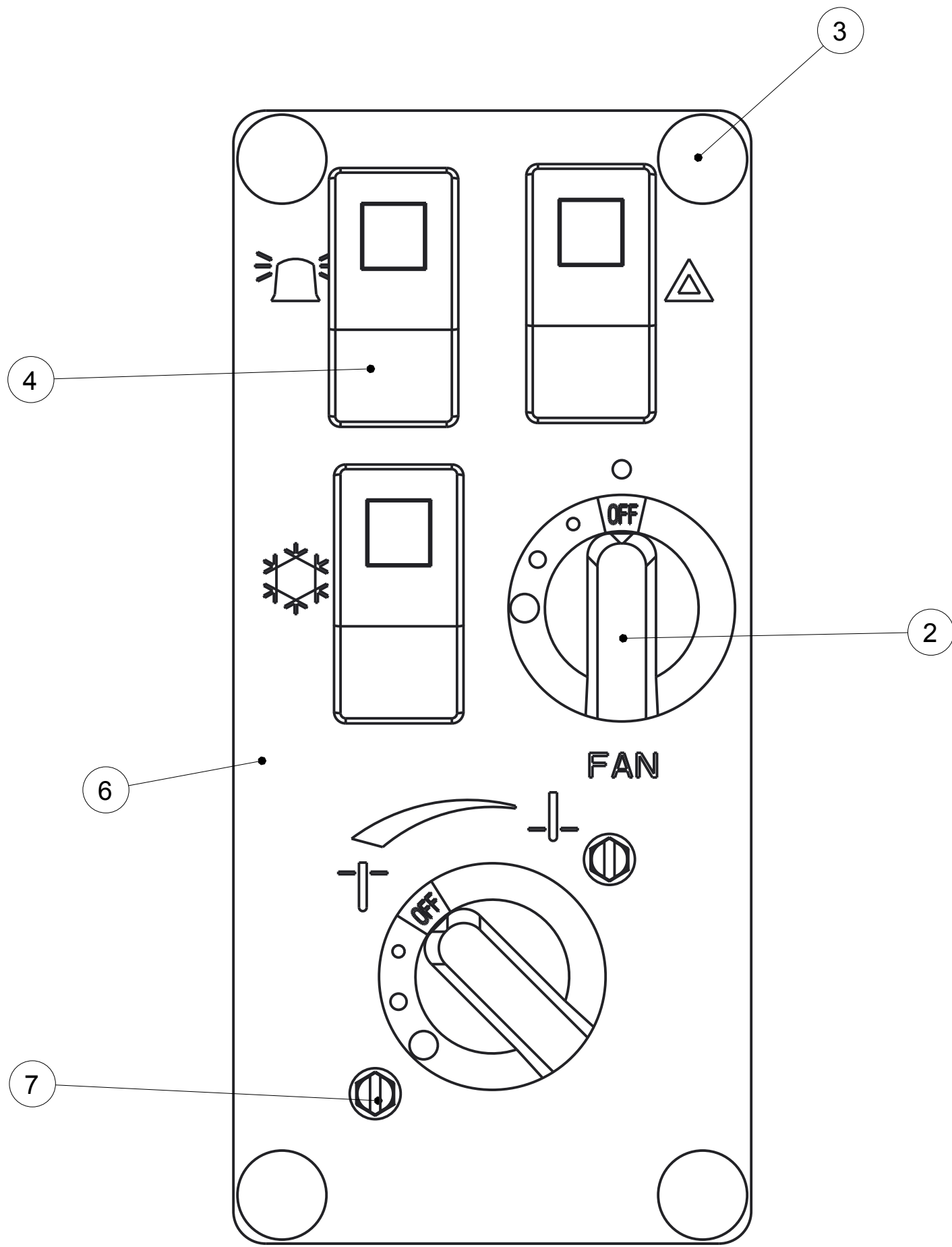

SCALE 1.000

Notice of Confidentiality

This material is property of Tektite Manufacturing Inc and is not to be used by the recipient for any purpose other than the purpose for which it was transmitted. The material remains the property of Tektite and shall be returned upon request. The material may not be reproduced or disclosed to third parties without the written consent of Tektite.

Tolerances:

Unless otherwise specified

X.X = ± 1/16"  
Angular = ± 1.0°

Tektite Manufacturing Inc.

24157 Hwy 3, Box 639, Winkler MB, R6W 4A8, Canada

Req'd:	CNC:	Description: <b>New Valve Design Switch Plate, 2014</b>	
Drawn By: <i>Daryl Furkalo</i>	Date: 2014-02-05	Units: <b>Imp.</b>	File Name: TEKT-ASM-030
Checked By:	Date:	Size: <b>B</b>	

Index	Service Part #	File Name	Description	Qty
1	A00-0055	TEKT-0019	Fir Tree Fastener	4
2	A00-0063	LEFT-CAB-SWITCHPLATE	Left Switchplate	1
3	A00-0064	LEFT-CAB-SWITCHPLATE-DECAL	Left Switchplate Decal	1
4	A00-0065	TEKT-ASM-005	On-Off Switch w/Lens	5
5	A00-0066	TEKT-ASM-006	On-Off-On Rocker No Lens	1
6	A00-0067	TEKT-ASM-007	Mom-Off-Mom Rocker Switch	1

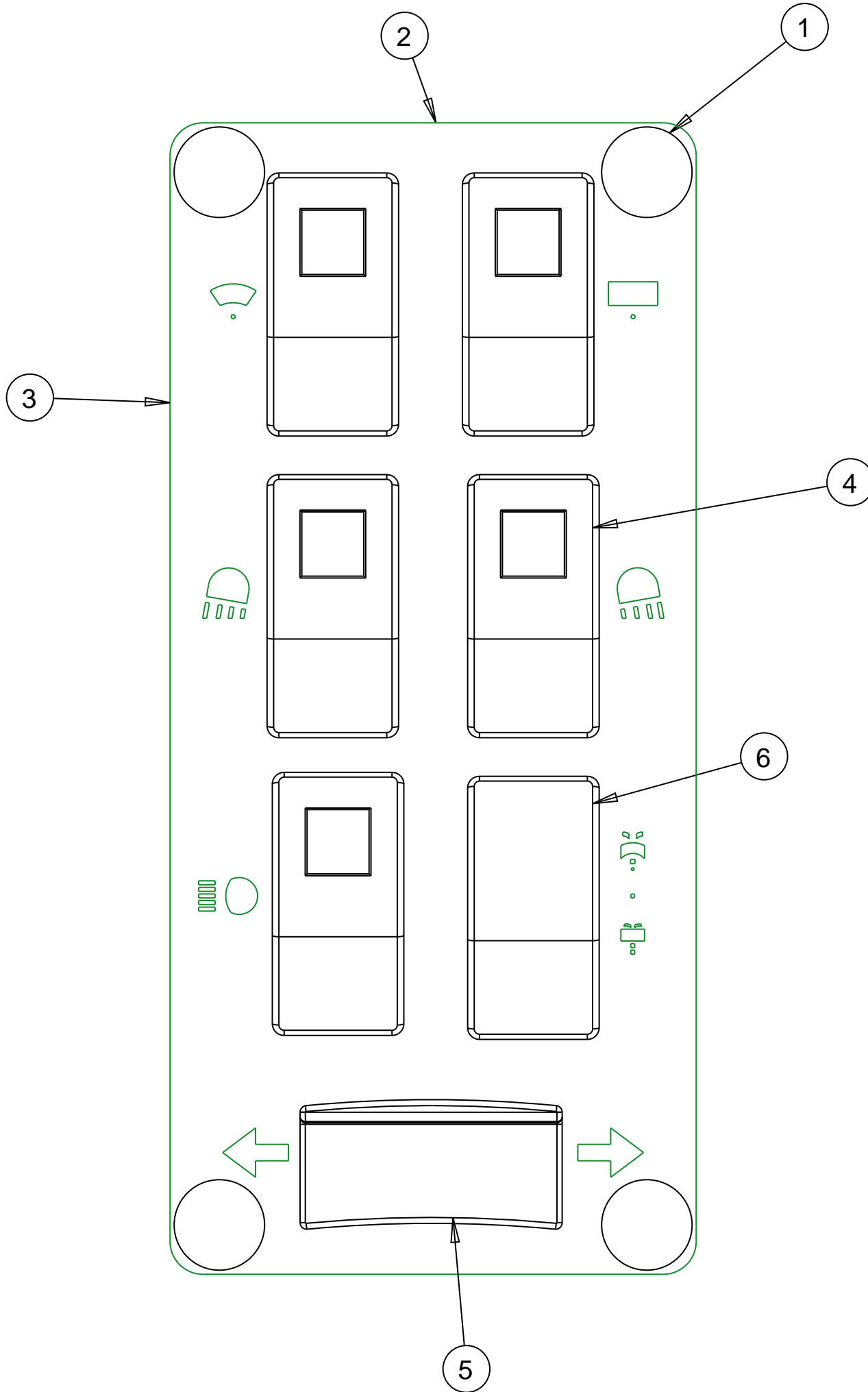

SCALE 1.000

Notice of Confidentiality

This material is property of Tektite Manufacturing Inc and is not to be used by the recipient for any purpose other than the purpose for which it was transmitted. The material remains the property of Tektite and shall be returned upon request. The material may not be reproduced or disclosed to third parties without the written consent of Tektite.

Tolerances:

Unless otherwise specified

X.X = ± 1/16"  
Angular = ± 1.0 °

Tektite Manufacturing Inc.

24157 Hwy 3, Box 639, Winkler MB, R6W 4A8, Canada

Req'd:	CNC:	Description: <b>Operator Manual Switch Plate Left</b>	
Drawn By: <i>Daryl Furkalo</i>	Date: 2009-03-09	Units: <b>Imp.</b>	File Name: LEFT-SWITCHPLATE-ASM
Checked By:	Date:	Size: <b>B</b>	

Index	Service Part #	File Name	Description	Qty
1	A00-0006	TEKT-0074	Cabin Air Filter	2
2	A00-0016	TEKT-0075	Domelight LED	1
3	A00-0017	305-1002	Panto Mount Plate	1
4	A00-0025	BALL-LOUVER	2 1/2" Ball Louver	4
5	A00-0026	OSCILLATING-FAN	Oscillating Fan	1
6	A00-0038	TEKT-0076	3" Plug	1
7	A00-0055	TEKT-0019	Fir Tree Fastener	2
8	A00-0070	REID-KBP-262-KBP-265	Knob, Knurled, 1/4"	6
9	A00-0071	LEFT-SWITCHPLATE-ASM	Left Switchplate Assembly	1
10	A00-0072	TEKT-ASM-030	Right Switchplate Assembly, 2014 Update	1
11	A00-0073	FILTER-COVER	Filter Cover	3
12	A00-0074	TEKT-ASM-004	Fuse Block Assembly	1
13	A00-0075	WWJ-MOTOR-ASM	Front Wiper Motor, WWJ	1
14	A00-0076	TEKT-0026	1/4" Panel Nut	6
15	A00-0081	KUF2880-HEADLINER-REV1	Headliner	1
16	A00-0082	KUF2880-049	Headliner Upholstery	1
17	A00-0083	KUF2880-060	Front Filter Upholstery	1
18	A00-0120	BLADE_24	Wiper Blade, 24"	1
19	A00-0140	PANTO_ARM_20	Wiper Arm, 20" Panto	1

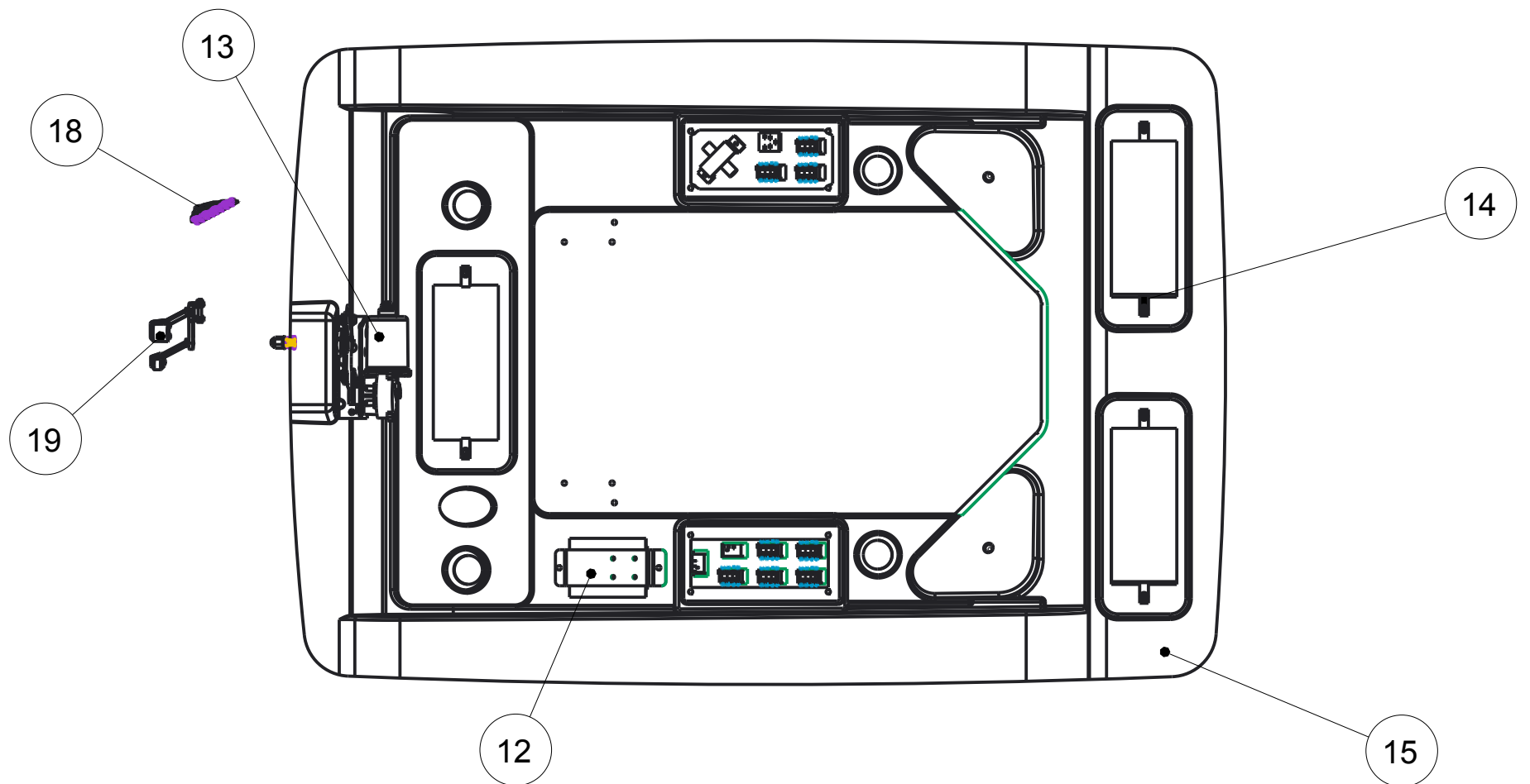
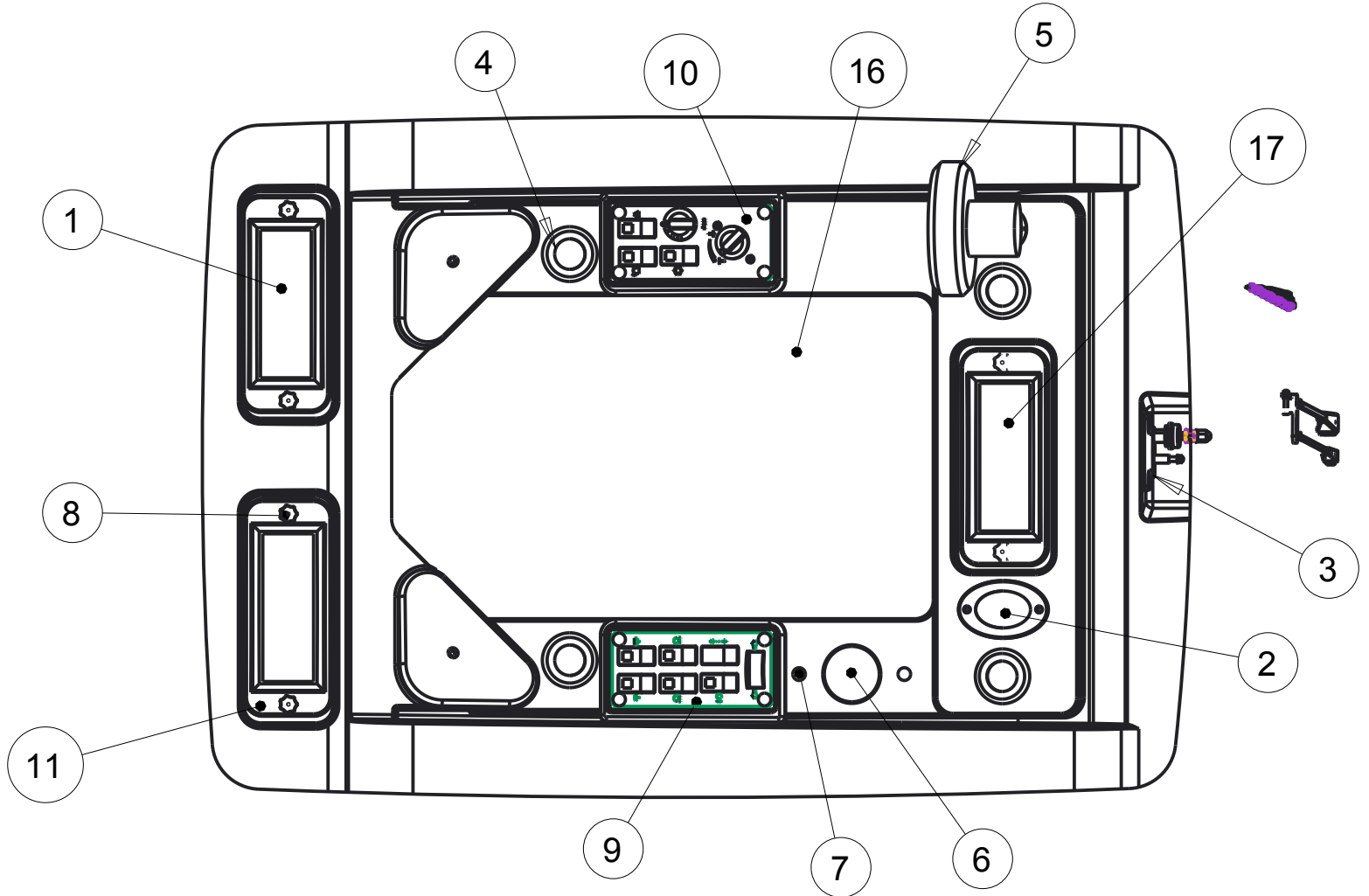

**Tektite Manufacturing Inc.**  
24157 Hwy 3, Box 639, Winkler MB, R6W 4A8, Canada

**Notice of Confidentiality**

This material is property of Tektite Manufacturing Inc and is not to be used by the recipient for any purpose other than the purpose for which it was transmitted. The material remains the property of Tektite and shall be returned upon request. The material may not be reproduced or disclosed to third parties without the written consent of Tektite.

**Tolerances:**  
Unless otherwise specified  
X.X = ± 1/16"  
Angular = ± 1.0°

Req'd:	CNC:	Description: <b>Headliner Assembly, Mowers</b>	
Drawn By: <i>Daryl Furkalo</i>	Date: 2014-01-02	Units: <b>Imp.</b>	File Name: TEKT-ASM-032
Checked By:	Date:	Size: <b>B</b>	

Index	Service Part #	File Name	Description	Qty
1	A00-0028	TEKT-0088	Red Dot Drier	1
2	A00-0081	TEKT-0216	Headliner	1
3	A00-0171	TEKT-0089	Binary Switch	1
4	A00-0482	TEKT-ASM-076	Elbow Louvre	4
5	A00-0483	TEKT-ASM-080	Kalori, Heater/AC, 4-Outlet	1
6	A00-0563	TEKT-ASM-091	Heater/AC Drip Tray, Final	1

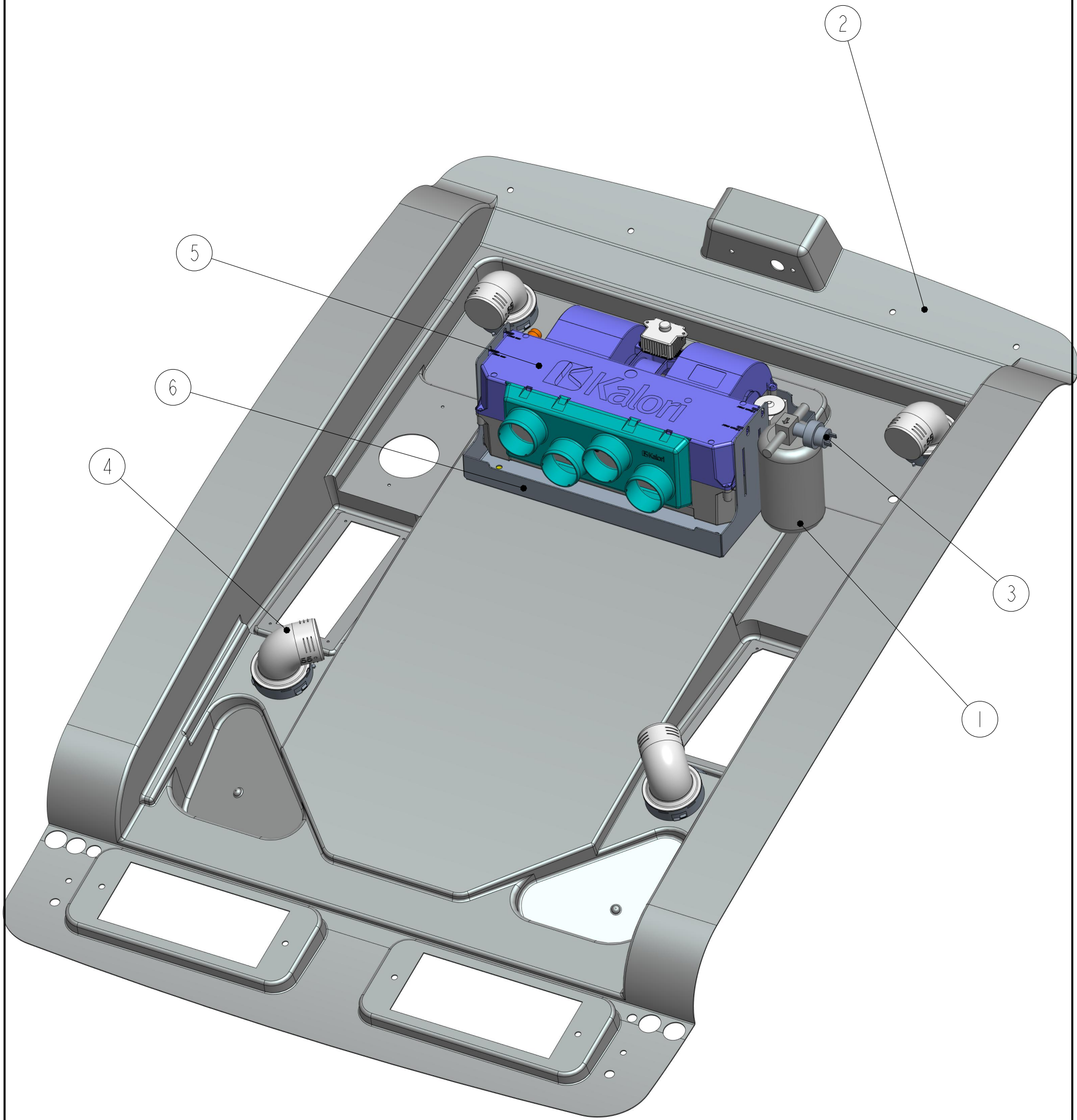

**Tektite Manufacturing Inc.**  
427 Buffalo Str, Box 639, Winkler MB, R6W 4A8, Canada

**Notice of Confidentiality**

This material is property of Tektite Manufacturing Inc and is not to be used by the recipient for any purpose other than the purpose for which it was transmitted. The material remains the property of Tektite and shall be returned upon request. The material may not be reproduced or disclosed to third parties without the written consent of Tektite.

**Tolerances:**  
Unless otherwise specified  
X.X =  $\pm 1/16"$   
Angular =  $\pm 1.0^\circ$

Req'd:	CNC:	Description: <b>A/C Compatible Additional Parts</b>	
Drawn By: <i>Daryl Furkalo</i>	Date: <b>2025-03-20</b>	Units: <b>Imp.</b>	File Name: <b>TEKT-ASM-020_AC-ASM</b>
Checked By:	Date:	Size: <b>B</b>	



Index	Service Part #	File Name	Description	Qty
1	A00-0008	TEKT-0077	Front Turn Signal Light LED, Amber	2
2	A00-0009	TEKT-0079	Oval LED Light Grommet	2
3	A00-0010	TEKT-0078	Round Grommet, LED Light	2
4	A00-0011	TEKT-0080	Round Turn Light	2
5	A00-0078	RED-DOT-CONDENSOR	Red Dot Condensor 77R1602	1
6	J01-0011	KUF2880-ROOF	Roof	1

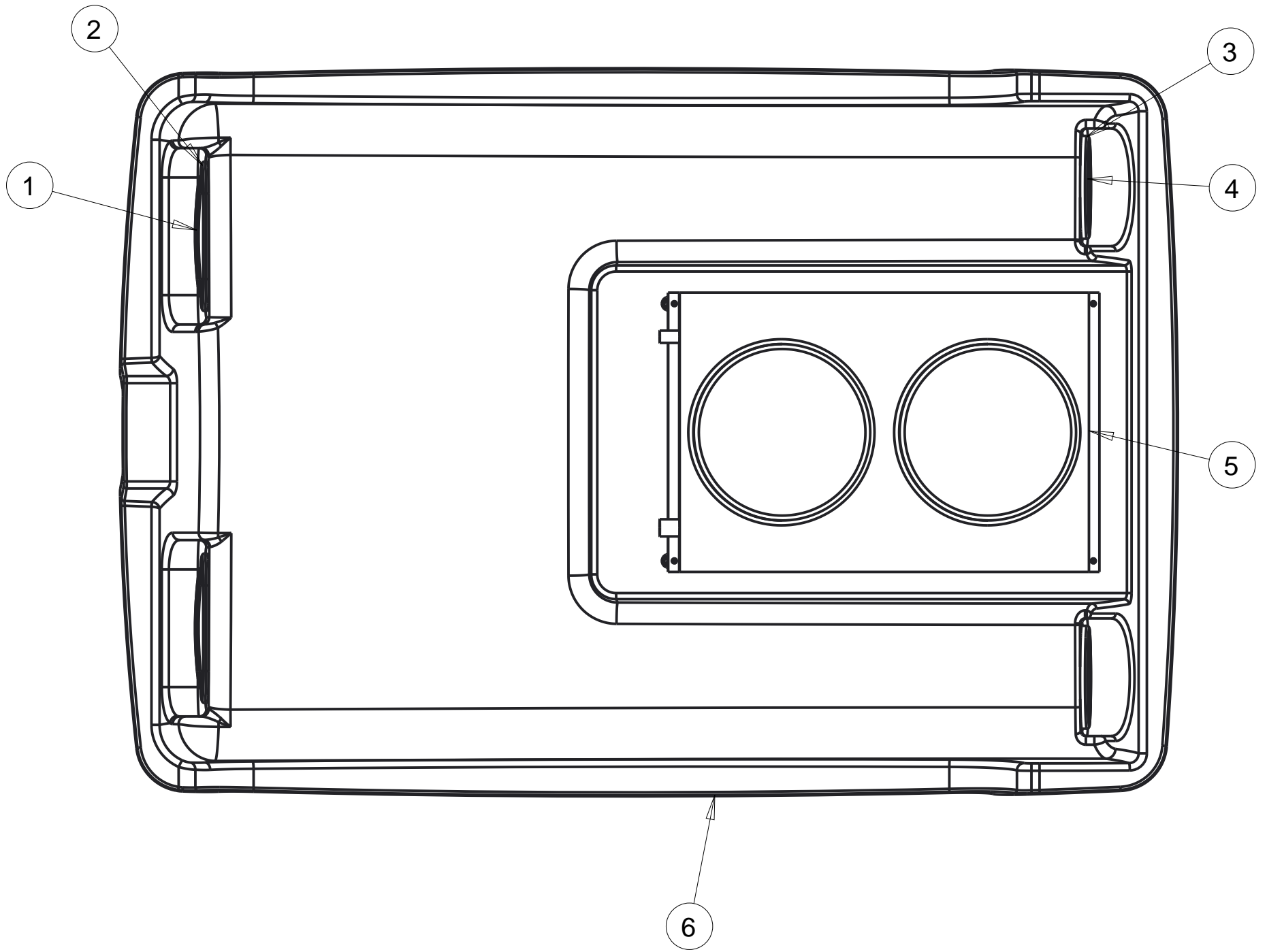

**Notice of Confidentiality**

This material is property of Tektite Manufacturing Inc and is not to be used by the recipient for any purpose other than the purpose for which it was transmitted. The material remains the property of Tektite and shall be returned upon request. The material may not be reproduced or disclosed to third parties without the written consent of Tektite.

**Tolerances:**

Unless otherwise specified

X.X =  $\pm 1/16"$   
Angular =  $\pm 1.0^\circ$

**Tektite Manufacturing Inc.**

24157 Hwy 3, Box 639, Winkler MB, R6W 4A8, Canada

Req'd:	CNC:	Description: <b>Roof Assembly</b>	
Drawn By: <i>Daryl Furkalo</i>	Date: 2013-02-01	Units: <b>Imp.</b>	File Name: KUF2880-ROOF-ASM
Checked By:	Date:	Size: <b>B</b>	

Index	Service Part #	File Name	Description	Qty
1	A00-0166	TEKT-0103	Condensor Fan	2
2	A00-0220	TEKT-0101	Base Condenser Coil	1
3	A00-0221	TEKT-0102	Condensor Assembly Steel Shroud	1

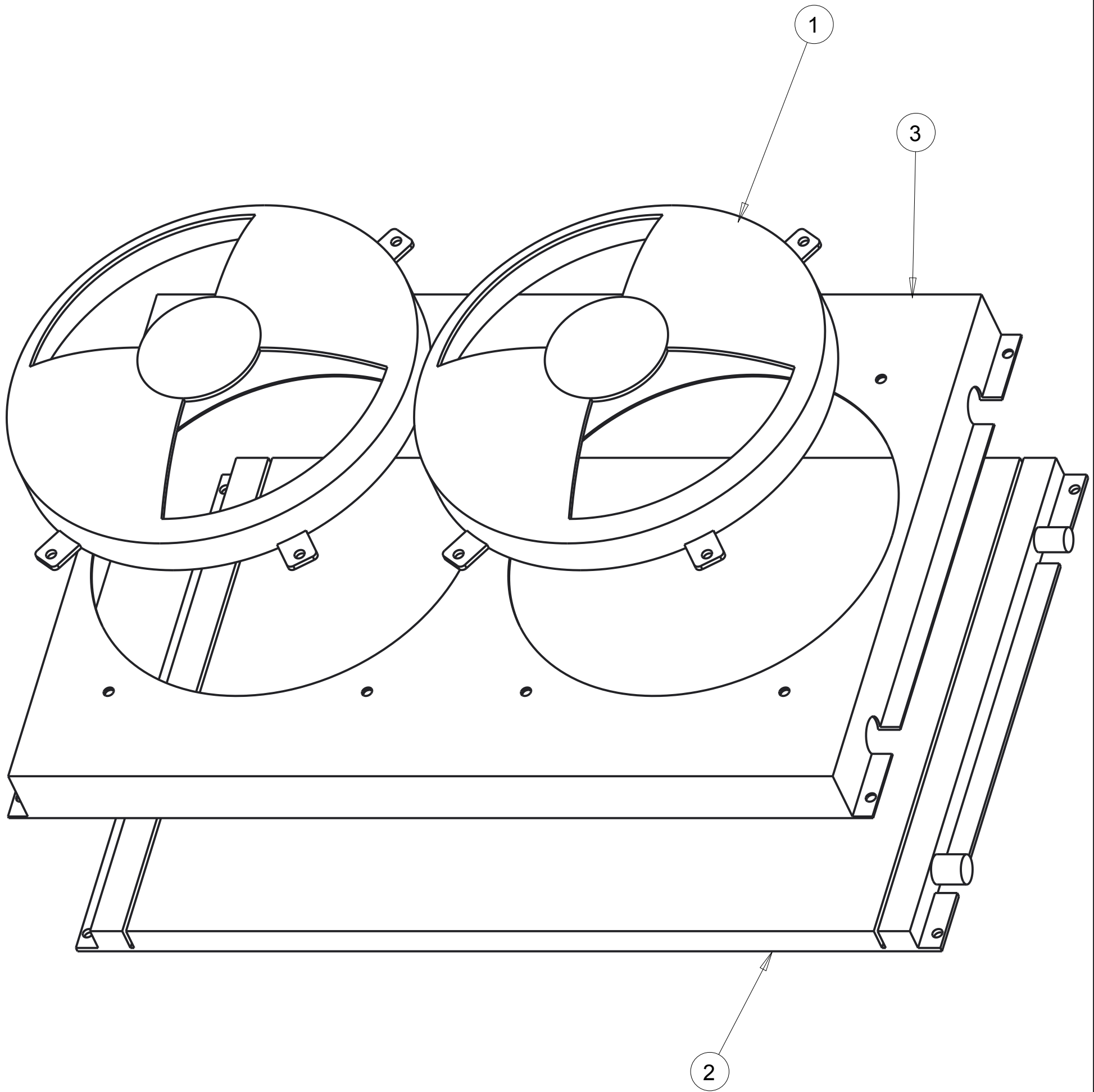

**Tektite Manufacturing Inc.**  
 24157 Hwy 3, Box 639, Winkler MB, R6W 4A8, Canada

**Notice of Confidentiality**

This material is property of Tektite Manufacturing Inc and is not to be used by the recipient for any purpose other than the purpose for which it was transmitted. The material remains the property of Tektite and shall be returned upon request. The material may not be reproduced or disclosed to third parties without the written consent of Tektite.

**Tolerances:**  
 Unless otherwise specified  
 X.X =  $\pm 1/16"$   
 Angular =  $\pm 1.0^\circ$

Req'd:				CNC:		Description:	
Drawn By:				Date:		Units:	
<i>Daryl Furkalo</i>				2013-07-04		Imp.	
Checked By:				Date:		Size:	
						B	
						File Name:	
						TEKT-ASM-026	
<b>Condensor Assembly Breakdown</b>							

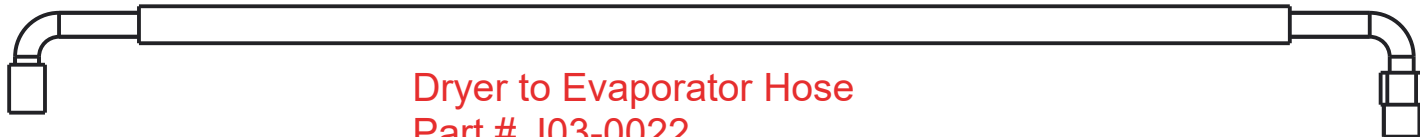

Dryer to Evaporator Hose  
Part # J03-0022

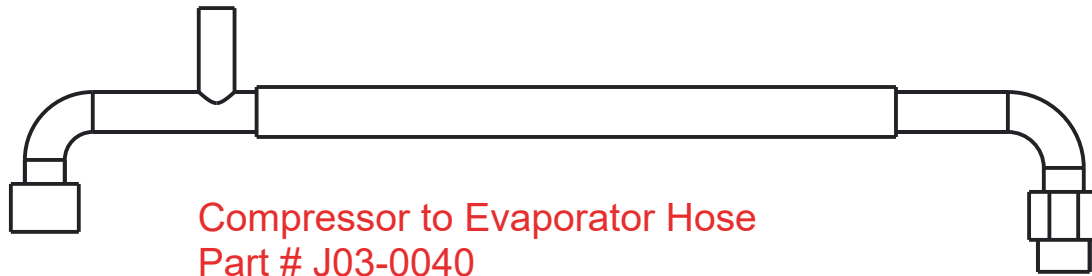

Compressor to Evaporator Hose  
Part # J03-0040

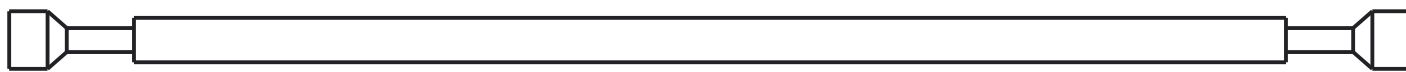

Condenser to Dryer Hose  
Part # J03-0021

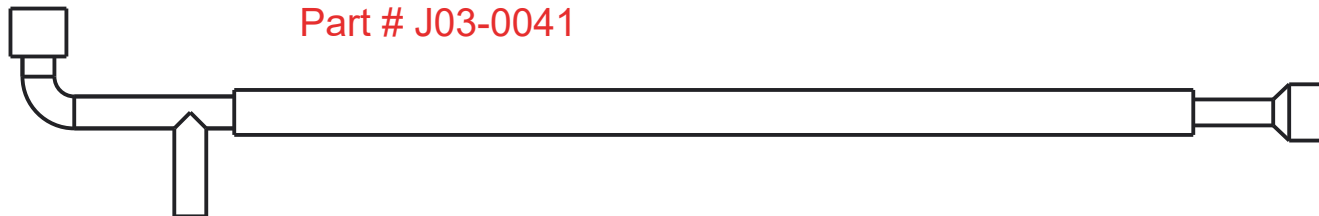

Compressor to Condenser Hose  
Part # J03-0041

Notice of Confidentiality

This material is property of Tektite Manufacturing Inc and is not to be used by the recipient for any purpose other than the purpose for which it was transmitted. The material remains the property of Tektite and shall be returned upon request. The material may not be reproduced or disclosed to third parties without the written consent of Tektite.

**Tolerances:**  
Unless otherwise specified  
X.X =  $\pm 1/16"$   
Angular =  $\pm 1.0^\circ$

<b>Tektite Manufacturing Inc.</b> 24157 Hwy 3, Box 639, Winkler MB, R6W 4A8, Canada			
Req'd: <b>1 req</b>		Description: <b>A/C Hoses Breakdown Series 3</b>	
Drawn By: <i>Daryl Furkalo</i>	Date: 2018-02-13	Units: <b>Imp.</b>	File Name:
Checked By:	Date:	Size: <b>B</b>	

Index	Service Part #	File Name	Description	Qty
1		JDWAM-ASM-018		1
2	A00-0023	FLANGE_BOLT_1-4X3-4	Flange Bolt, 1/4" x 3/4", YD	4
3	A00-0061	TEKT-0021	Striker Mounting Plate	2
4	A00-0084	TEKT-0070	Gas Shock	2
5	A00-0085	TEKT-0069	Gas Shock Stud	2
6	A00-0101	STRIKER-PIN	Striker Pin	2
7	A00-0103	HEX-NUT-M12X1	Hex Nut, M12 x 1.0, YD	2
8	A00-0131	TEKT-0181	External Fuel Cap	1
9	A00-0371	TEKT-0175	New LED Work Light (Blazer Intl)	2
10	A00-0413	FLANGE-NUT-5-16	Flange Nut, 5/16", YD	2

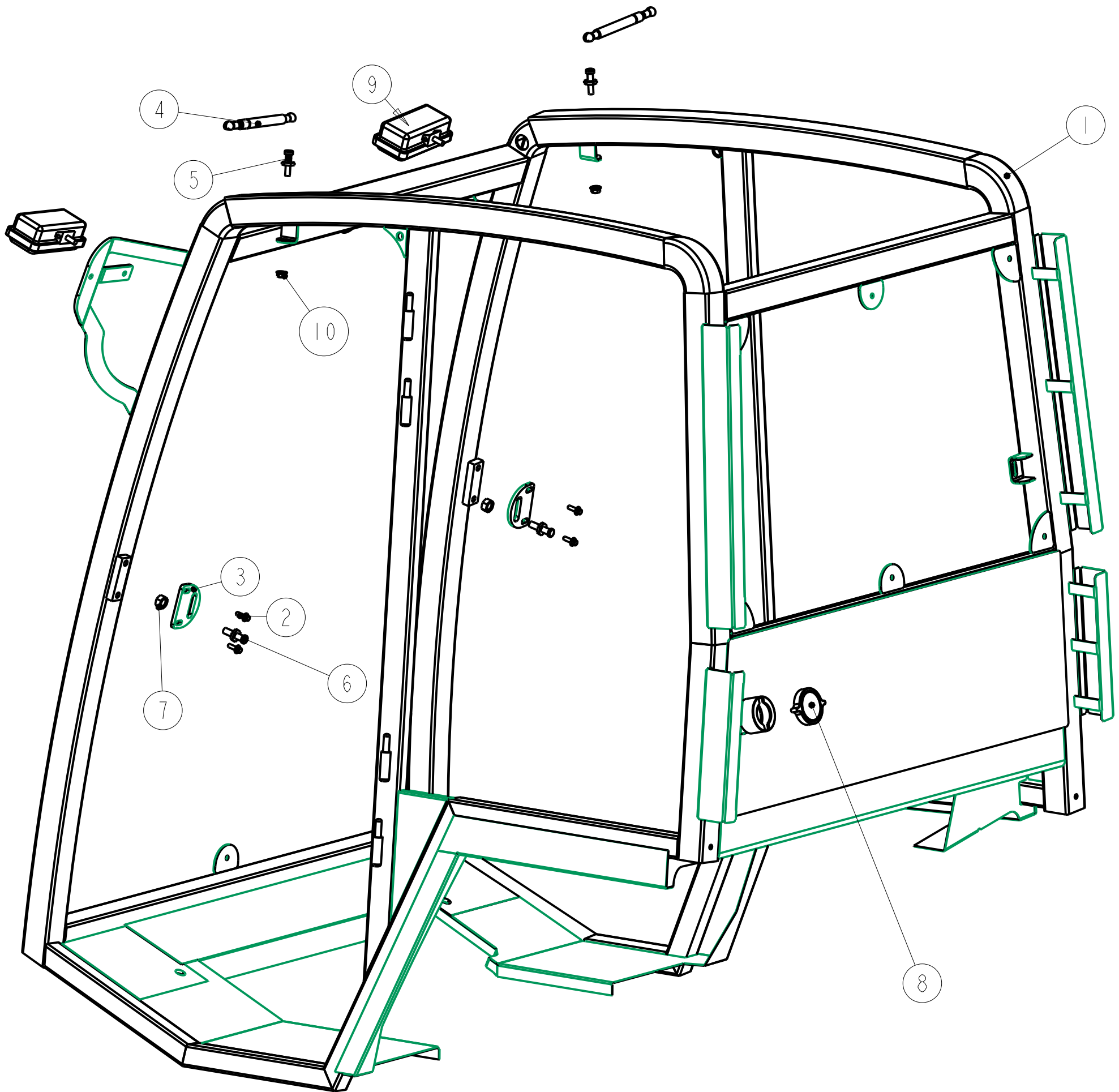

**Tektite Manufacturing Inc.**  
427 Buffalo Str, Box 639, Winkler MB, R6W 4A8, Canada

**Notice of Confidentiality**

This material is property of Tektite Manufacturing Inc and is not to be used by the recipient for any purpose other than the purpose for which it was transmitted. The material remains the property of Tektite and shall be returned upon request. The material may not be reproduced or disclosed to third parties without the written consent of Tektite.

**Tolerances:**  
Unless otherwise specified  
X.X = ±1/16"  
Angular = ± 1.0°

Req'd:	CNC:	Description:	
		<b>Accessories Assembly</b>	
Drawn By: <i>Daryl Furkalo</i>	Date: <b>2025-03-20</b>	Units: <b>Imp.</b>	File Name: <b>JDWAM-ASM-039</b>
Checked By:	Date:	Size: <b>B</b>	

Index	Service Part #	File Name	Description	Qty
1	A00-0019	STEP-BOLT1-4X1	Step Bolt, 1/4" x 1", MB	1
2	A00-0021	FLANGE-NUT-1-4	Flange Nut, 1/4", YD	1
3	A00-0519	TEKT-0244	Rectangular Mirror	1
4	A00-0521	M12X1.75_NYLOCK_NUT	Nylon Lock Nut, M12 x 1.75	1
5	A00-0536	TEKT-0250	Spacer For Interior Mirror	1
6	A00-0537	CARRIAGE_BOLT_M12X50	Carriage Bolt, M12 x 50	1
7	A00-0582	TEKT-0270	Plastic Top Mirror Magic	1

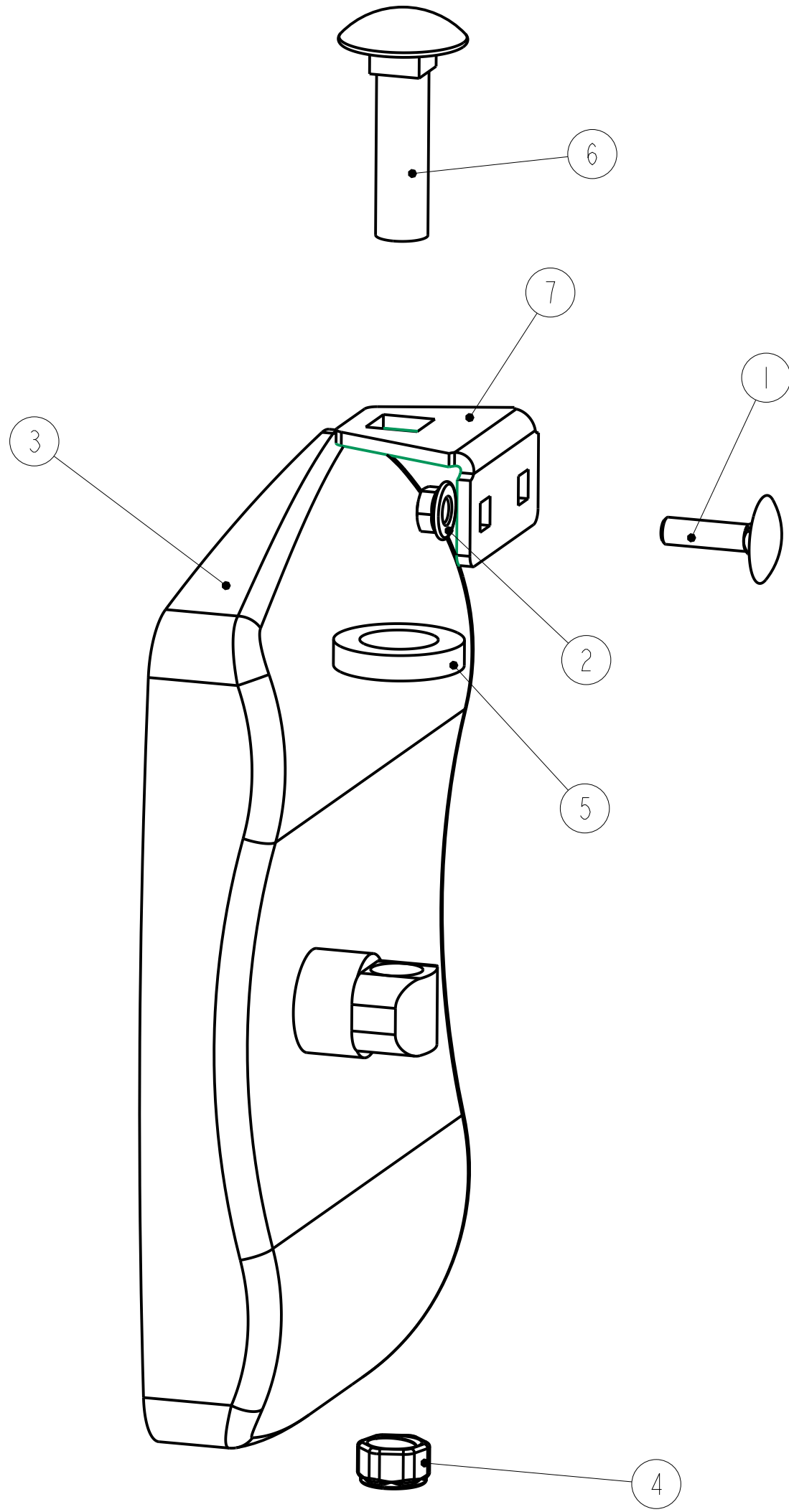

**Notice of Confidentiality**

This material is property of Tektite Manufacturing Inc and is not to be used by the recipient for any purpose other than the purpose for which it was transmitted. The material remains the property of Tektite and shall be returned upon request. The material may not be reproduced or disclosed to third parties without the written consent of Tektite.

**Tolerances:**  
 Unless otherwise specified  
 X.X =  $\pm 1/16"$   
 Angular =  $\pm 1.0^\circ$

**Tektite Manufacturing Inc.**  
 427 Buffalo Str, Box 639, Winkler MB, R6W 4A8, Canada

Req'd: <b>L&amp;R</b>	CNC:	Description: <b>Exterior Mirror L&amp;R Assembly</b>	
Drawn By: <i>Ana Laura Peters</i>	Date: <b>2025-03-05</b>	Units: <b>Imp.</b>	File Name: <b>TEKT-ASM-099_OP</b>
Checked By: <b>Daryl Furkalo</b>	Date: <b>2025-03-19</b>	Size: <b>B</b>	